

ULTRASHRINK™ 2818 DIP TANK

Introducing another all NEW addition to our existing line of quality Koch Equipment packaging machines: the UltraShrink 2818 Dip Tank. This new stainless steel shrink tank was designed to provide high-quality contoured retail packaging for meat, poultry, cheese, and other perishable food products.

The UltraShrink 2818 eliminates dog ears and excessive wrinkles around food products that have been vacuum packaged in shrink bags. The economical UltraShrink 2818 is built in the USA and comes with Koch Equipment's standard two-year warranty.

Standard Features

- Stainless steel
- Electric heat
- Programmable temperature control/sensor
- Simple push button cycle operation
- On/off indicator light
- Easy access for cleaning and maintenance
 - High performance insulation to avoid heat loss
 - Thermal insulation balls
 - Easy fill and drain tank
 - Low energy consumption
 - Made in USA
 - ETL/Approved to UL & CSA Standards
 - Two year warranty

Power Requirements

| Voltage | Required Service |
|--------------------|------------------|
| 208, 60Hz, 3-phase | 50 Amps |
| 240, 60Hz, 3-phase | 50 Amps |
| 460, 60Hz, 3-phase | 30 Amps |
| 380, 50Hz, 3-phase | 30 Amps |
| 575, 60Hz, 3-phase | 20 Amps |

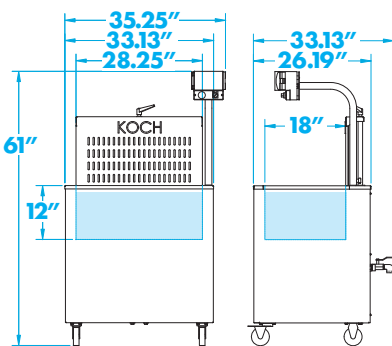
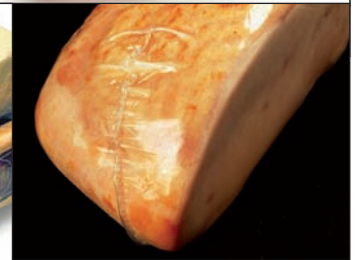

Technical Specifications

| | |
|-------------------------|---|
| Outside Dimensions | 61" H x 35.25" L x 33.13" W (1550mm x 895mm x 842mm) |
| Cycle Time | 2 seconds / optional variable speed (1.5 - 3.0) |
| Immersion Platform Size | 28.25" L x 18" W (718mm x 457mm) |
| Immersion Depth | 10" (254mm) |
| Tank Volume | approx. 30 gallons |
| Maximum Load Capacity | 50-lbs. (22.7kg) |
| Net Weight (empty) | 320-lbs. (145kg) |

www.thescaleshop.net

1-888-844-2031