

HEATSEAL

SHRINK PACKAGING SYSTEMS

MODEL HS-1520

CONSOLE L SEALER



Shown As: HS-1520D With Optional Perforating Roller

**PROVIDES STRONG, CONSISTENT
SEALS WITH ALL TYPES
OF CENTERFOLDED FILM**

Features of the HS-1520 Console L Sealer

- Standard 115 Volt Power Supply With Ground Fault Indicator
- 15" By 20" Sealing Area
- Temperature Compensating Solid State Seal Controller
- Quick Change Sealing Wire Tension Assembly
- Heavy Duty Seal Head Design With Film Clamps
- U.L. Listed Control Panel (File No. E146586)
- Console Leg Kit With 3" Locking Casters
- Shipped With Leg Kit Attached Ready To Use
- Adjustable Height Wrapping Platform
- Heavy Gauge Steel Construction
- USDA Approved Stainless Steel Model Available (HS-1520S)

STANDARD DUTY SERIES

Machine Specifications

| | |
|---------------------------|--|
| Film Capacity | 17" (44 cm) |
| L-Bar Area | 15" W, 20" L (38 W, 51 L cm) |
| Overall Dimensions | 23" W, 49" L, 49" H (58 W, 124 L, 124 H cm) |
| Working Height | 35" (89 cm) |
| Power Requirements | 115V, 15 amp Single Circuit With Ground |
| Weight | 185 lbs (84 kg) (Net w/Most Popular Options) |

Machine Footprint

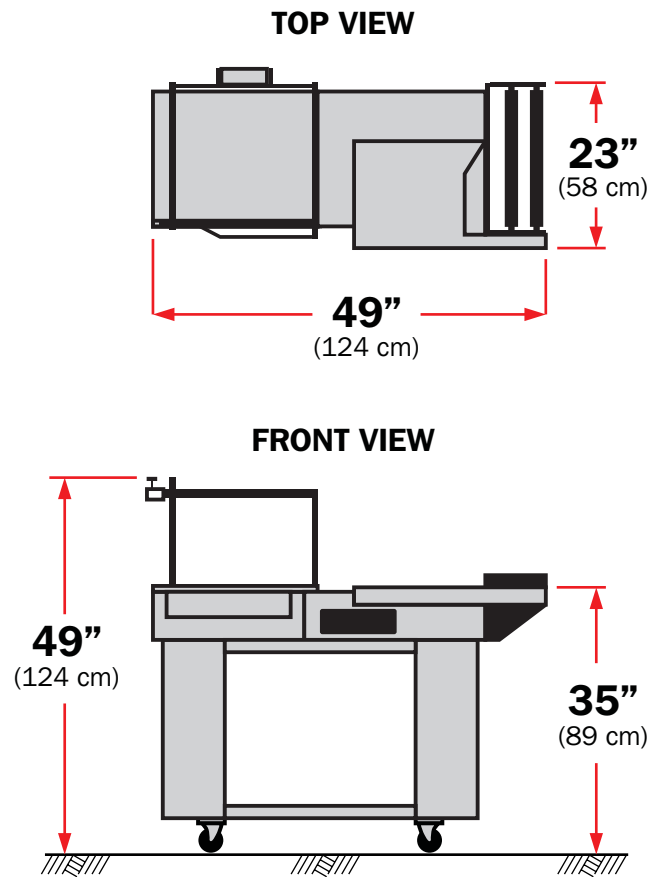

Machine Options

- Perforating Roller (Adjustable)
- Heated Hole Punch
- Film Separator Rod (For 6" Film Opening)
- Spare Parts Kit
- Export Wiring
- Air-Actuated Arm (Magnetic Hold Down Required)
- Single Magnet Hold Down With Dwell
- Dual Magnet Hold Down With Dwell
- Adjustable Inverting Head With Manual Film Unwind And Perforating Roller
- Adjustable Inverting Head With Powered Film Unwind And Perforating Roller
- 20" Film Capacity
- Dual Film Rack
- Posi-Trac Power Take Away Conveyor
- Soft-Start For Power Take Away Conveyor
- Roller Product Bed
- 5" Casters
- Power Take Away Ready - Pre Wired
- Left Handed (Reverse Flow)
- Stainless Steel Construction
- Silicone Belt PTA (In Lieu Of Posi-Trac PTA)
- Storage Drawer
- 40" Long Seal Area (HS - 1540)
- 60" Long Seal Area (HS - 1560)
- 80" Long Seal Area (HS - 1580)
- 100" Long Seal Area (HS-15100)



www.thescaleshop.net

1-888-844-2031

MODEL HS-1520 STANDARD DUTY