

# HEAT SEAL

## SHRINK PACKAGING SYSTEMS

### **MODEL HS-1515**

#### **CONSOLE L SEALER**

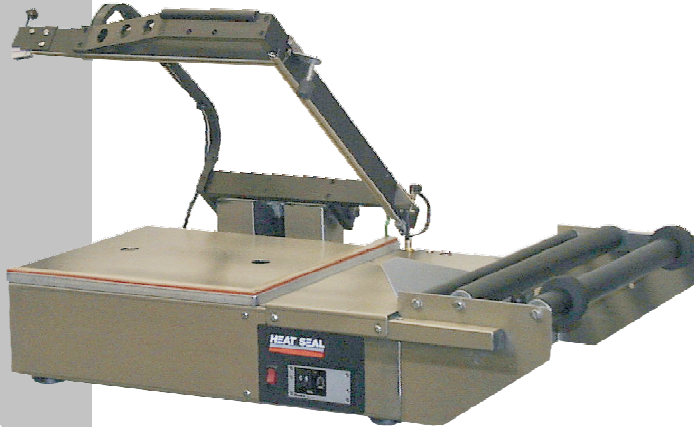

Shown As: HS-1515 Stainless Steel

**PROVIDES STRONG, CONSISTENT  
SEALS WITH ALL TYPES  
OF CENTERFOLDED FILM**

**CAN BE SHIPPED UPS**

#### **Features of the HS-1515 Table Top L Sealer**

- Standard 115 Volt Power Supply With Ground Fault Indicator
- 15" By 15" Sealing Area
- Temperature Compensating Solid State Seal Controller
- Quick Change Sealing Wire Tension Assembly
- Heavy Duty Seal Head Design
- High Quality Sealing Pad Design
- U.L. Listed Control Panel (File No. E146586)
- Highly Portable, Easily Moved
- Adjustable Height Wrapping Platform
- Heavy Gauge Steel Construction
- USDA Approved Stainless Steel Model Available (HS-1515S)

STANDARD DUTY SERIES

## Machine Specifications

<b>Film Capacity</b>	<b>17" (44 cm)</b>
<b>L-Bar Area</b>	<b>15" W, 15" L</b> (38 W, 38 L cm)
<b>Overall Dimensions</b>	<b>21" W, 29" L, 22" H</b> (53 W, 74 L, 56 H cm)
<b>Power Requirements</b>	<b>115V, 15 amp Single Circuit With Ground</b>
<b>Weight</b>	<b>55 lbs (25 kg)</b> (Net w/Most Popular Options)

## Machine Footprint

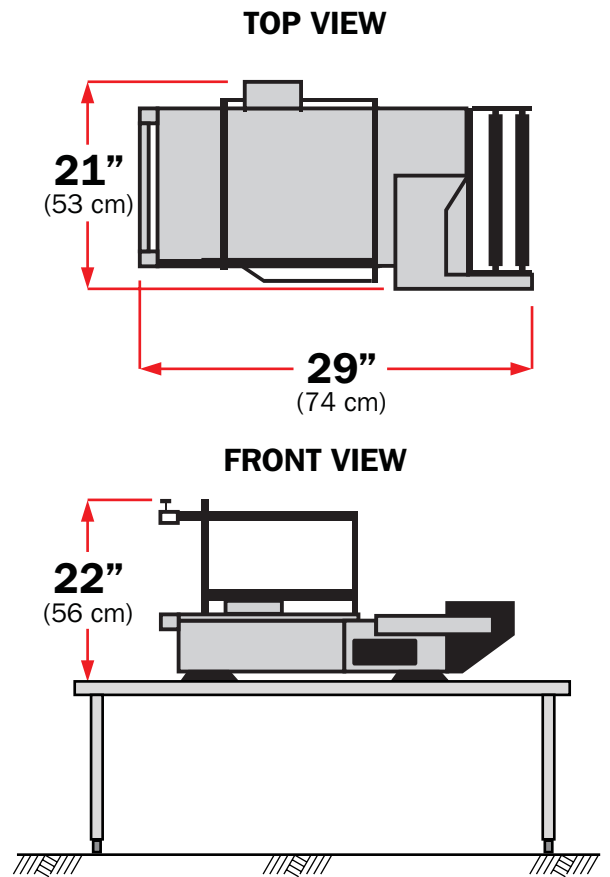

## Machine Options

- Perforating Roller (Adjustable)
- Heated Hole Punch
- Film Separator Rod (For 6" Film Opening)
- Single Magnet Hold Down With Dwell
- 15" By 19" Seal Area (Factory Installed Only)
- Spare Parts Kit
- Export Wiring
- Stainless Steel Construction
- Special Paint Color



[www.thescaleshop.net](http://www.thescaleshop.net)

1-888-844-2031