

# HEATSEAL

## SHRINK PACKAGING SYSTEMS



### MODEL HDS-320

SEMI-AUTOMATIC COMBINATION  
SHRINK SYSTEM

HEAVY DUTY CONSTRUCTION  
THROUGHOUT

STANDARD IMPULSE SEAL  
WITH OPTIONAL HOT KNIFE

#### FEATURES AVAILABLE ON THE HDS-320

- Standard 220 Volt Power Supply
- Top Mounted, Easy Access UL Listed Control Panel
- RS-3 Digital Controller For Easy System Setup And Operation With Built In Diagnostics And Alarms
- Large 20" by 20" Sealing Area - Ideal for Printers
- Cast Aluminum Seal Head With Film Clamps
- Adjustable Seal Pads
- Dual Magnets With Adjustable Dwell Time
- Posi-Trac Power Take Away Conveyor
- Film Perforator With Individually Adjustable Collars
- Adjustable Film Cradle
- 8" H by 21½" W Tunnel Opening (12" High Opening Optional)
- 6,000 Watt Tunnel With Bottom Air Flow
- Tunnel Heating Elements Guaranteed For Ten Years
- Live/Dead Roller Tunnel Conveyor Also Available With Stainless Steel Wire Mesh, Teflon Mesh Or Solid Silicone Heated Tunnel Conveyor Belts
- Package Centering Lateral Tunnel Conveyor Alignment System
- Smooth Product Transfer From Power Take Away To Tunnel With Single Hand Crank Height Adjustment
- Built In Automatic Tunnel Cool Down
- Heavy Duty Casters And Levelers
- Stainless Steel Model Available

HEAVY DUTY SERIES

## Machine Specifications

<b>Film Capacity</b>	24" W (61 cm)
<b>L Bar Seal Area</b>	20" W, 20" L (51 W, 51 L cm)
<b>Tunnel Chamber Dimensions</b>	8" H, 21.5" W, 28" L (20 H, 55 W, 71 L cm)
<b>Overall Dimensions</b>	57" H, 38" W, 83" L (145 H, 97 W, 211 L cm)
<b>Working Height</b>	38" (97 cm)
<b>Power Requirement</b>	208/220V, 25 Amps Single Circuit w/Ground
<b>Wattage</b>	6,000 Watts
<b>Tunnel Conveyor Speed</b>	LDR: 0-35/70 ft./min. TMB/SWB: 0-30 ft./min.
<b>Weight</b>	800 lbs. (363 kg)

## Machine Footprint

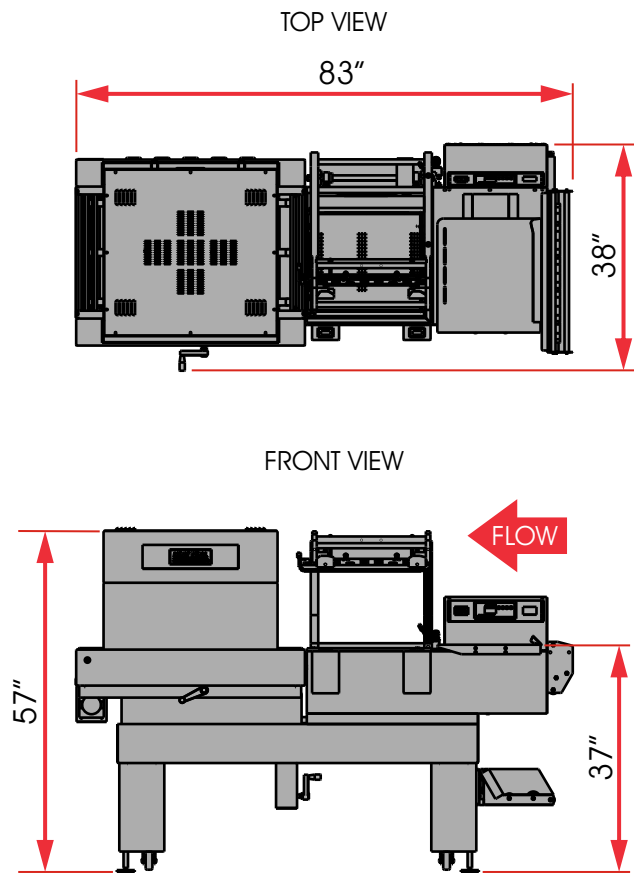

## Machine Options

- 12" High Shrink Tunnel Opening
- Hot Hole Punch
- Powered Lift/Posi-Trac Power Take Away Conveyor
- Adjustable Hot Hole Punch With Articulated Arm
- Corrugated Loading Tray
- Left Handed Reverse Flow
- Stainless Steel Construction
- Ceramic Bead Impulse Seal System
- Spare Parts Kit
- Air Activated Sealing Head
- Powered Film Unwind With Perforating Roller And 6" Adjustable Inverting Head
- GTC-90 And GTC-180 Gravity Turn Around Conveyors
- Powered Accumulator Tables
- High Density Live/Dead Roller Spacing



[www.thescaleshop.net](http://www.thescaleshop.net)

1-888-844-2031



MODEL HDS-320 HEAVY DUTY SERIES