

# HEATSEAL

®

## SHRINK PACKAGING SYSTEMS

### **MODEL HDS-115**

#### **SEMI-AUTOMATIC COMBINATION SHRINK SYSTEM**



**HEAVY DUTY CONSTRUCTION  
THROUGHOUT**

**STANDARD IMPULSE WIRE OR  
BEADED SEAL SYSTEM AVAILABLE**

#### **Features Available on the HDS-115**

- Standard 115 Volt Power Supply With GFI Protection
- Top Mounted, Easy Access U.L. Listed Control Panel
- Standard Microprocessor Acc-U-Seal Wire Temp Control
- Large 15" By 20" Sealing Area, Ideal For Printers
- Cast Aluminum Seal Head With Film Clamps
- Easily Adjustable Seal Arm Height
- Adjustable Seal Pads
- Dual Magnets With Adjustable Pressure And Dwell Time
- Posi-Trac Power Take Away Conveyor
- Film Perforator With Individually Adjustable Collars
- Adjustable Film Cradle
- Exterior Cool To The Touch Tunnel Insulation
- Acc-U-Temp Digital Tunnel Temperature Control
- 6" High By 15" Wide Tunnel Opening (8" High Optional)
- Adjustable Heat Tunnel Conveyor Belt For Bottom Shrink Control
- 2,500 Watt Tunnel
- Built In Automatic Tunnel Cool Down
- Synchronized Power Take Away And Tunnel Conveyor Height Adjustments Allow For Smooth Product Transition
- Package Centering Lateral Tunnel Conveyor Alignment System
- Heavy Duty Casters And Levelers
- Stainless Steel Model Available

HEAVY DUTY SERIES

## Machine Specifications

<b>Film Capacity</b>	<b>20" Wide</b> (51 cm)
<b>L Bar Seal Area</b>	<b>15" W, 20" L</b> (38 W, 51 L cm)
<b>Inside Tunnel Dimensions</b>	<b>6" H, 14 1/2" W, 21" L</b> (15 H, 37 W, 53 L cm)
<b>Overall Dimensions</b>	<b>57" H, 29" W, 76" L</b> (145 H, 74 W, 193 L cm)
<b>Working Height</b>	<b>37" (94 cm)</b>
<b>Power Requirement</b>	<b>115 Volts, 20 Amp Single Circuit with Ground</b>
<b>Wattage</b>	<b>2,000 Watts: Tunnel 500 Watts: Conveyor Belt</b>
<b>Tunnel Conveyor Speed</b>	<b>0-20 Feet Per Minute</b>
<b>Weight</b>	<b>625 lbs. (284 kg)</b>

## Machine Footprint

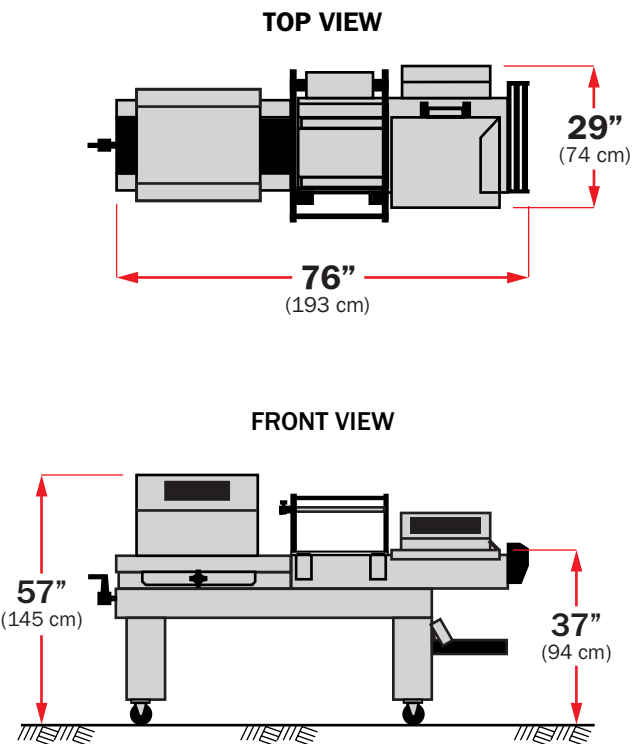

## Machine Options

- 8" High Tunnel Opening
- Hot Hole Punch
- 6" Film Separator Rod
- Dual Film Rack
- Powered Lift/Posi-Trac Power Take Away Conveyor
- Extended Seal Area (15" By 24")
- Left Hand Reverse Flow
- Export Wire: 220 Volts
- Adjustable Hot Hole Punch With Articulated Arm
- Roller Drip Pan Or Corrugated Loading Tray
- Stainless Steel Construction
- Beaded Seal Impulse Wire System
- Spare Parts Kit
- Air Activated Seal Head
- High Performance, 220 Volt, 3,600 Watt Tunnel
- Powered Unwind With Perforating Roller And 6" Adjustable Inverting Head
- GTC-180/GTC-90 Gravity Turn Around Conveyors
- Powered Accumulator Tables



[www.thescaleshop.net](http://www.thescaleshop.net)

1-888-844-2031