

# **BIRO**

## ***Our Equipment Works Harder So You Don't Have To***

A 60 lb. meat block can be chipped in less than 60 seconds.

Save approximately 2-1/2 lbs. of meat from each chipped meat block.

Bloom qualities are uniform and excellent.

No measurable chipper product loss.

Better utilization of other cutting machinery for retail processing.

Better utilization of man power for other productive duties.

Reduce saw blade usage.

Extra handling of meat sticks is eliminated.

Planned productivity is assured.

Quality control is maintained.

Minimum product shrinkage occurs.

Minimum operational heat is generated.

Better bloom.

Extends case life.



# **FBC-4800 55**



*Stands alone for quality  
and value since 1921*

### SPECIFICATIONS

**MODEL** FBC-4800SS TEMPERED FROZEN BLOCK CHIPPER  
**CONSTRUCTION** STAINLESS STEEL CONSTRUCTION  
**MOTOR**

HP	KW	TYPE	VOLTS	AMPS	CYCLE	PHASE	STATUS
5	3.75	OP	208-230/460	16-15/7.5	60	3	STD
5	3.75	OP	220/380-415	15/8.7-7.9	50	3	STD
5	3.75	OP	575	6	60	3	EC

OP= OPEN      STD=STANDARD      EC=EXTRA COST

**SWITCH** MAGNETIC TYPE WITH LOW VOLTAGE AND OVERLOAD PROTECTION.

**TRANSMISSION** OIL BATH WITH HEAVY DUTY BRONZE GEAR FITTED DIRECTLY TO MOTOR.

**STANDARD EQUIPMENT** POLYETHYLENE PRODUCT RECEPTACLE, PRODUCT RECEPTACLE DOLLY, FLOOR BOLT DOWN LOCATOR CHOCKS, OPERATING AND SAFETY MANUAL.

**OPTIONS (EC)** STAINLESS STEEL DISCHARGE CHUTES, LONGER AND WIDER LEGS FOR PRODUCT DISCHARGE INTO BIRO CONVEYOR. CALL FACTORY

**OPERATION** MAXIMUM BLOCK SIZE 8" (203 MM) X 16-1/2" (419 MM) X 19-1/2" (495 MM).  
RECOMMENDED BLOCK TEMPERATURE 15° TO 25° F OR 10° TO 4° C. CAN REDUCE BLOCK INTO CHIPS APPROXIMATE 3-1/2" (89 MM) X 3-1/2" (89 MM) X 1/4" (6.4 MM) IN LESS THAN 60 SECONDS.

**CLEANING** ENTIRE LID OPENS FOR EASY ACCESS, ENTIRE KNIFE SHUTTLE ASSEMBLY REMOVABLE AS A UNIT FOR CLEANING.

**CERTIFICATIONS** N.S.F. -U.L. -C.S.A. -USDA

**WEIGHT** UNCRATED: 533 LBS. APPROXIMATE  
CRATED: 610 LBS. (277 KG) APPROXIMATE

**DIMENSIONS CRATED** L = 54" (137 CM), W = 45" (114 CM), H = 38" (96.5 CM)  
(LEGS ARE FOLDED UP FOR SHIPPING)

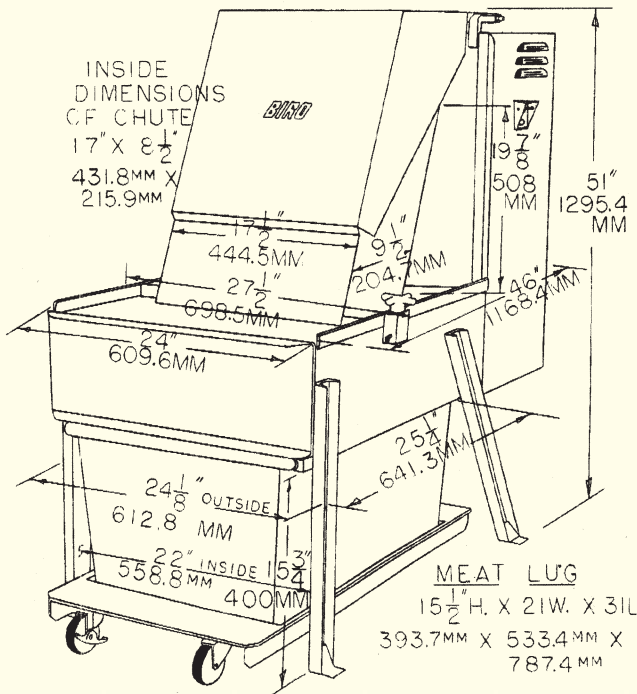

THIS INFORMATION REPRESENTS OUR BEST JUDGEMENT BASED ON WORK DONE AND TEST PERFORMED. THE BIRO MANUFACTURING COMPANY ASSUMES NO LIABILITY WHATSOEVER IN CONNECTION WITH THE USE OF THE INFORMATION OR FINDING CONTAINED HEREIN.



[www.thescaleshop.net](http://www.thescaleshop.net)

1-888-844-2031