

# BIRO

 **SCALES SHOP**  
customized weighing and packaging systems

## *Known For Reliability For Over 89 Years*

Cut chicken, turkey, duck, fish, and rabbit all day with the Biro BCC-100 Poultry Cutter. The special 9" cutting blade lets you cut pieces accurately while providing minimal tearing of the skin. You achieve almost no cutting loss and almost no product shrink. Since the blade is designed to slice instead of tear product tissue, your shelf life is maximized.

The 3/4 horsepower motor ensures that you have all of the power you need, and the machine design lets you cut for maximum productivity. The BCC-100 is designed for easy wash down and good sanitation. Left hand design machines are available if your product flow requires it.



KNIFE GUIDE TROUGH  
NOT SHOWN

# BCC-100



*Stands alone for quality  
and value since 1921*

## SPECIFICATIONS

MODEL  
CONSTRUCTION  
MOTORS

BCC-100 POULTRY CUTTER.  
STAINLESS STEEL BASE, COLUMN, EXTENSION SHAFT.

MOTORS	VOLTS	CYCLE	PH	AMPS	STANDARD OR OPTIONAL
3/4 HP (.5 kw)-TE	115/230	60	1	10.8/5.4	Standard
3/4 HP (.5 kw)-TE	115/230	50	1	12.0/6.0	Extra Cost
3/4 HP (.5 kw)-TE	208-230/460	60	3	2.9-2.7/1.4	Extra Cost
3/4 HP (.5 kw)-TE	190/380	50	3	3/1.5	Extra Cost

### STANDARD FEATURES

KNIFE BLADE SHARPENER, 5' CORD AND 3 PRONG PLUG ON 115 VOLT, 5' CORD NO PLUG ON 208-230/460 VOLT, KNIFE GUIDE TROUGH, OPERATING AND SAFETY MANUAL.

### SWITCH

TILT TYPE, ENCLOSED, WATERPROOF.

### INTERLOCK SWITCH

MICRO TYPE, ENCLOSED, WATERPROOF.

### KNIFE BLADE

STAINLESS STEEL, 9" (228 MM) DIAMETER, DOUBLE BEVEL.

### CUTTING GUIDE BAR

APEX TYPE, STAINLESS STEEL 1" (25 MM) DIAMETER.

### KNIFE GUIDE TROUGH

STAINLESS STEEL, STANDARD.

### OPTIONS (EC)

LEFT HAND UNIT (BLADE ON LEFT SIDE OF MOTOR), SERRATED KNIFE BLADE (IN PLACE OF STANDARD KNIFE BLADE), CALIFORNIA STATE REQUIREMENT.

### COUNTER SPACE REQUIRED CERTIFICATION

18" (457 MM) L X 18-1/2" (470 MM) W X 22" (560 MM) H.  
U.S.D.A.

### WEIGHT

UNCRATED: 75 LBS. (35.4 KG) APPROXIMATE.  
CRATED: 83 LBS. (37.7 KG) APPROXIMATE.

### DIMENSIONS CRATED

L = 20" (508 MM) W = 23" (584 MM) H = 21" (533 MM).

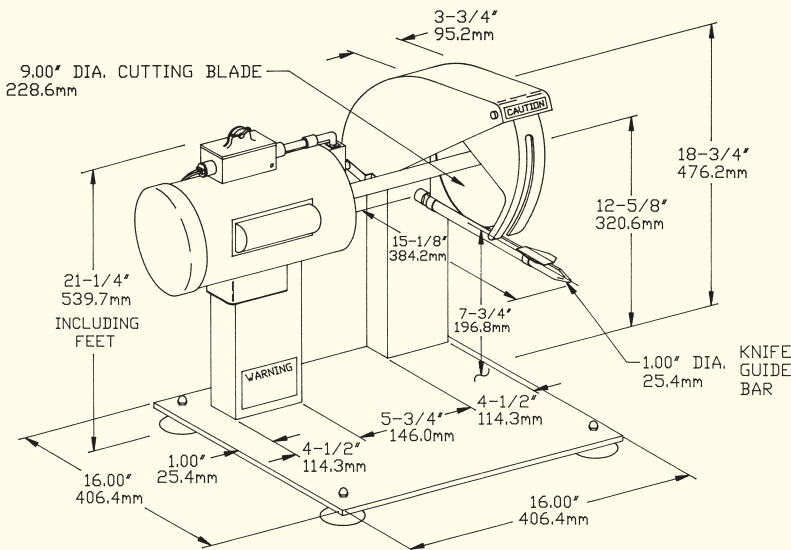

*Bird poised to remove wings through natural knuckle point of dissection.*



*Thigh and drumstick right side, poised for removal.*



*Right drumstick and thigh removal.*



[www.thescaleshop.net](http://www.thescaleshop.net)

1-888-844-2031

ALL SPECIFICATIONS CONTAINED HEREIN ARE SUBJECT TO CHANGE WITHOUT NOTIFICATION.