

JAOP10

“Superior *quality* product at an *affordable* price !”

OVEN : 10 pans baking capacity
PROOFER : 12 pans capacity

Standard Features

- Outstanding steam shot and pulse injection system
- Exclusive patented reversing fan system
- Two speeds fan
- Fan delay switch
- Compact space saving unit
- High production oven
- Full view heat reflective thermos glass doors
- Brightly lit
- Digital reminder timer
- Fully insulated, completely sealed
- Digital temperature controllers and timers
- Temperature up to a maximum of 500°F (260°C)
- Energy efficient electric or gas heating (baking temperature reached in 15 minutes)
- Magnetic latches
- Door switch cutoff for fan motor
- Stainless steel inside and outside
- Locking casters
- 3/4 HP motor
- ETL & NSF listed
- One year parts and labor limited warranty

Proofer Features

- Holds from 90° F to 110° F (32°C to 43°C) with relative humidity up to 95 %
- Glass doors
- Rust proof, scratch proof shelving
- Automatic water float system (no water pans to fill)
- Brightly lit
- Magnetic latches
- Stainless steel inside and outside

Optional

- Sliding doors
- Water softener system
- Programmable controls (adds 2" (51 mm) to oven width)
- Gas quick disconnect kit (4' (1220 mm) flexible hose, ball valve and securing device)
- Electronic relative humidity control on proofer

All JAOP ovens can be used to cook meat



JAOP10



Standard oven control



Optional programmable oven control



Standard proofer control



Optional relative humidity proofer control

JET AIR OVEN PROOFER JAOP10

The JAOP series from Doyon is known worldwide for its unique and patented Jet Air System (the air moves in one direction for 2.5 minutes, stops for 25 seconds than moves the other way for 2.5 minutes) resulting in a gentle velocity air flow for exceptional baking results. This system will help you bake faster and more evenly. Our competitors ovens allow the air to move in one direction only.

Doyon’s outstanding uniform steam injection system includes an electronic timer which will give you a precise mist everytime for a better quality product (crusty breads, bagels, french baguettes, etc.). This superior steam system will allow inexperienced employees to produce quality products with a minimum of training.

Doyon’s proofer provides uniform proofing from top to bottom with its even air flow system and fully automatic humidity injection (no water pans to fill). It comes with heat and humidity controls. It’s the easiest way to proof.

VERSATILITY

Bread, rolls, buns, crusty breads, pastries, muffins, cakes, pies, bagels, croissants, sours & ryes, bacon, game hens, chicken, turkey, multimeal prep, bulk vegetables, casseroles, slow cook, retherm.

DIMENSIONS

JAOP10 53 1/4"W X 48 3/4"D X 73"H
 (1353 mm X 1238 mm X 1854 mm)
 JAOP10G 53 1/4"W X 53 5/8"D X 73"H
 (1353 mm X 1362 mm X 1854 mm)

OVEN INTERIOR DIMENSIONS

JAOP10 39"W X 30 3/4"D X 26 1/2" H
 (991 mm X 781 mm X 673 mm)
 JAOP10G 39"W X 29 3/4"D X 26 1/2" H
 (991 mm X 756 mm X 673 mm)
 Shelf spacing : 3 3/4" (95 mm)

PROOFER INTERIOR DIMENSIONS

39"W X 30"D X 27" H
 (991 mm X 762 mm X 686 mm)
 Shelf spacing : 3" (76 mm)

GAS SYSTEM (JAOP10G Propane or natural)

BTU total : 85 000 BTU
 1 Phase:
 120/208V - 19.5 A - 4.5 kW - 3 wires - 60 Hz

Gas Inlet : 1/2" NPT
 Draft hood : 4" (102 mm)

Recommended gas pressure:
 Propane gas : 11" W.C.
 Natural gas : 7" W.C.

ELECTRICAL SYSTEM (JAOP10)

1 Phase:
 120/208V - 78 A - 16.5 kW - 3 wires - 60 Hz
 120/240V - 70 A - 16.5 kW - 3 wires - 60 Hz
 3 Phases:
 120/208V - 50 A - 16.5 kW - 4 wires - 60 Hz
 120/240V - 47 A - 16.5 kW - 4 wires - 60 Hz
 Other voltages available

Water Inlet : 1/4" NPT

Minimum clearance from combustible material
 1" (25 mm) side and back
 4" (102 mm) bottom
 12" (305 mm) top

CAPACITY

Oven
 Standard sheet pans 18" X 26" (457 mm X 660 mm) : 10 pans
 Four-strapped bread pans : 36 loaves
 9" (229 mm) : 50 pies
 Proofer
 Standard sheet pans 18" X 26" (457 mm X 660 mm) :12 pans
 Four-strapped bread pans :64 loaves

FINISH

Stainless steel

SHIPPING WEIGHT

JAOP10 1175 lb (533 kg) approximately
 JAOP10G 1340 lb (608 kg) approximately

Electrical service connection and water inlet are located at the back of the unit.
 Specifications and design subject to change without notice.

JAOP10

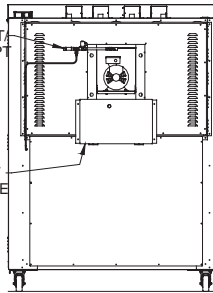
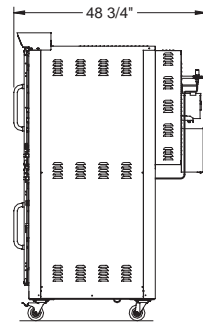
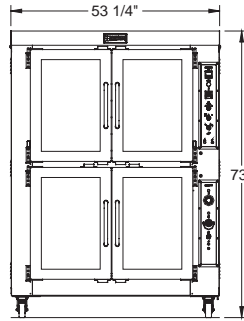

JAOP10G

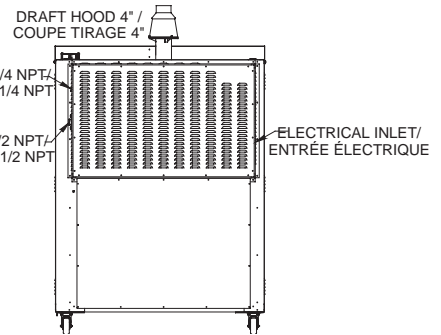
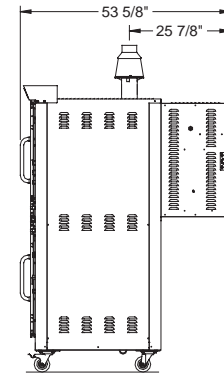
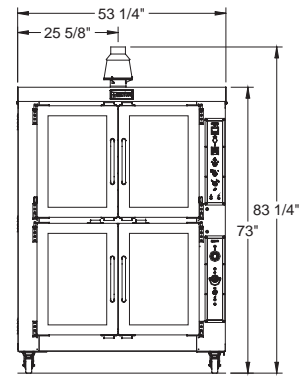

www.thescaleshop.net

1-888-844-2031