

# BOWL CUTTERS

## MODEL K80

Bowl cutting produces as much as 15% higher finished product yield. Bowl cutting also allows the use of up to 30% more water and results in less shrinkage.

### STANDARD

- 2 independent motors (bracket knife and bowl).
- Two 2 speed motors
- 6 knife head and compensating rings to use for 3 -knife head.
- Anti-noise lid
- All stainless steel

### OPTIONAL

- Optional slow knife mixing speed in 2 directions.
- Extracting arm with motorized disc to unload to a trolley

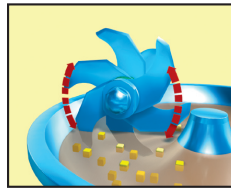

Optional slow knife mixing speed in 2 directions.



Standard removable 6 and 3-knife head.



Optional motorized unloader

### SPECIFICATIONS

<b>Model</b>	<b>K80</b>
<b>Bowl Volume</b>	80 L / 21 gal
<b>Mixture Bowl Capacity (approx.)</b>	65 kg./143.3 lbs.
<b>Knife Horsepower</b>	14.3/20.4HP
<b>Knife Speed</b>	2200/4300 RPM
<b>Bowl Horsepower</b>	2/3.4 HP
<b>Bowl Speed</b>	11/21 RPM
<b>Electrical</b>	220V/60/3
<b>Weight</b>	2425 lbs.
<b>Shipping Weight</b>	2860 lbs.
<b>Dimensions (LWH)</b>	57" x 82.3" x 50"
<b>Shipping Dimensions</b>	96" x 66" x 60"
<b>Item #</b>	10880

### DIMENSIONS

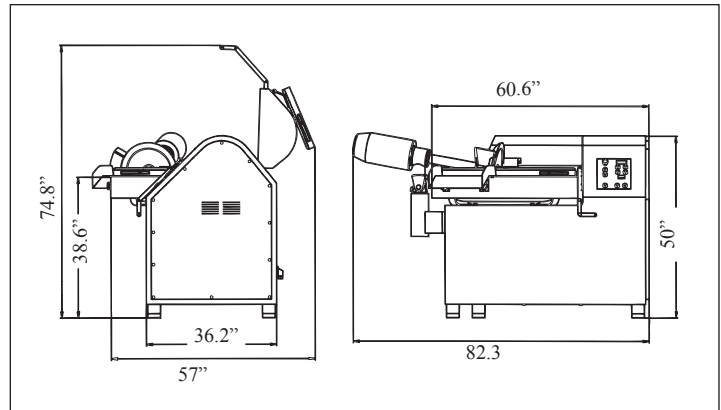

[www.thescaleshop.net](http://www.thescaleshop.net)

1-888-844-2031