

# BOWL CUTTERS



## MODEL K50

Bowl cutting produces as much as 15% higher finished product yield. Bowl cutting also allows the use of up to 30% more water and results in less shrinkage.

### STANDARD

- 2 independent motors (bracket knife and bowl).
- Two 2 speed motors
- 6 knife head and compensating rings to use for 3 -knife head.
- Anti-noise lid
- All stainless steel

### OPTIONAL

- Optional slow knife mixing speed in 2 directions.

### SPECIFICATIONS

|  |                      |
|--|----------------------|
| <b>Model</b>                           | <b>K50</b>           |
| <b>Bowl Volume</b>                     | 50 L / 13 gal        |
| <b>Mixture Bowl Capacity (approx.)</b> | 37 kg./81.5 lbs.     |
| <b>Knife Horsepower</b>                | 12/15 HP             |
| <b>Knife Speed</b>                     | 2200/4300 RPM        |
| <b>Bowl Horsepower</b>                 | 0.7/1.5 HP           |
| <b>Bowl Speed</b>                      | 11/21 RPM            |
| <b>Electrical</b>                      | 220V/60/3            |
| <b>Weight</b>                          | 1322.75 lbs.         |
| <b>Shipping Weight</b>                 | 1650.00 lbs.         |
| <b>Dimensions (LWH)</b>                | 46.4" x 49.2" x 47.2 |
| <b>Shipping Dimensions</b>             | 56" x 58" x 56"      |
| <b>Item #</b>                          | 10879                |



Front lid

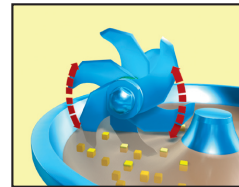

Optional slow knife mixing speed in 2 directions.



Standard removable 6 and 3-knife head.

### DIMENSIONS

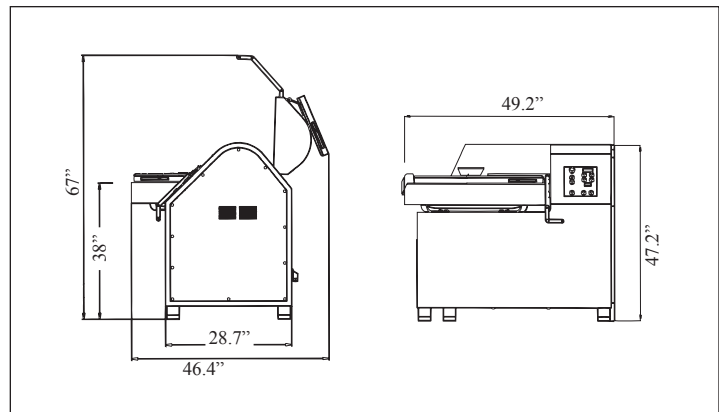

[www.thescaleshop.net](http://www.thescaleshop.net)

1-888-844-2031