

# BIRO®

**SCALES SHOP**  
customized weighing and packaging systems

## ***Known For Reliability For Over 89 Years***

Biro's Model 11, 10" Power Cutter is equipped with a 1½ HP motor and toggle switch as standard. A powder coated steel base, with aluminum head and door structures are standard. The removable platter and meat carriage are stainless steel.

Designed for use in small delis, meat shops, small grocery stores and restaurants. Excellent for boneless meats, chicken and pork chop cutting.

Proven design concepts with the durability and reliability found on other Biro Power Cutters. Strong load bearing components. Biro's single flange wheel concepts protect the blades set and teeth. Disassembles for easy cleaning without tools and is economical to use.

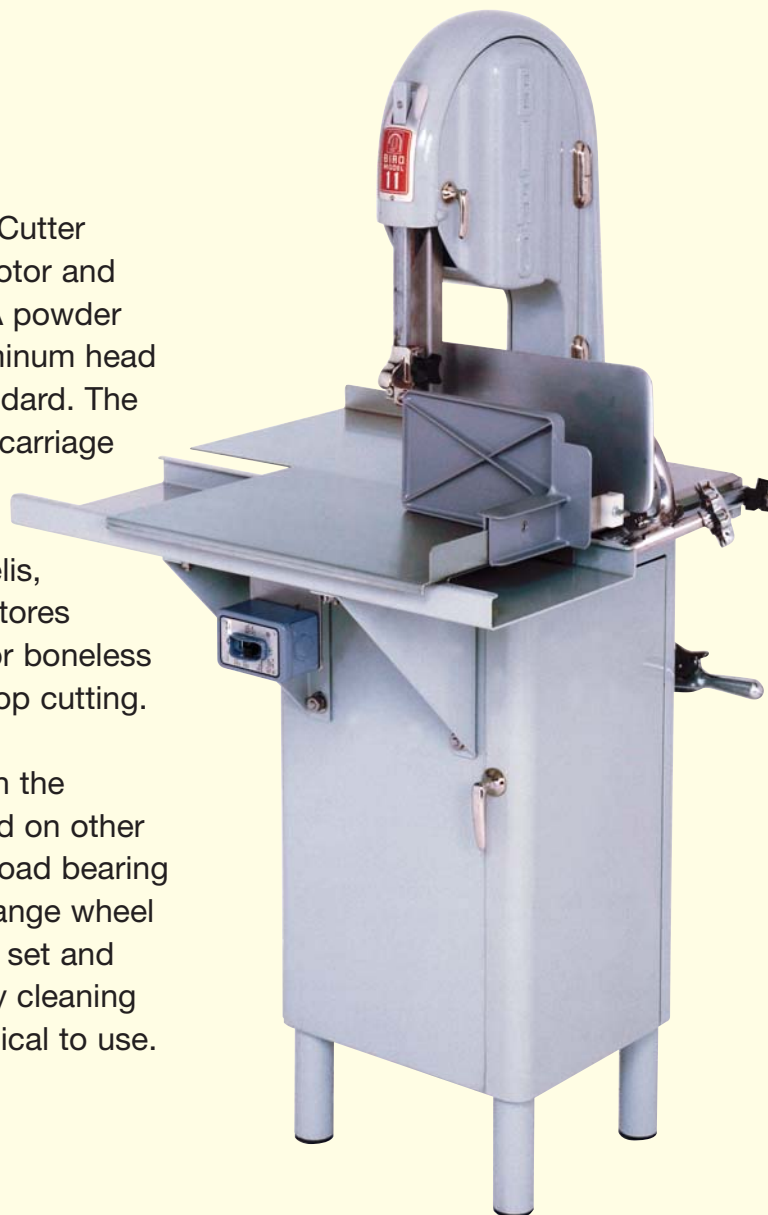

11



*Stands alone for quality  
and value since 1921*

## SPECIFICATIONS

**MODEL** 11 POWER CUTTER (10")  
**CONSTRUCTION** STEEL PLATE POWDER COATED BASE, ALUMINUM HEAD.  
**MOTORS**

HP	KW	TYPE	VOLTS	AMPS	CYCLE	PH	STATUS
1 1/2	1.1	HH	115/208-230	21/11/10.5	60	1	STD
1 1/2	1.1	HH	208-220/440	6-5.6/2.8	60	3	STD
1 1/2	1.1	HH	115/208-230	20/10-11	50	1	EC
1 1/2	1.1	TE	115/208-230	20/10-11	60	1	EC
1 1/2	1.1	TE	208-220/440	6-5.6/2.8	60	3	EC
1 1/2	1.1	HH	220/380/415	6/3.6-3.2	50	3	STD
1 1/2	1.1	TE	220/380/415	6/3.6-3.2	50	3	EC

TE= TOTALLY ENCLOSED STD=STANDARD  
 HH= HIGH HUMIDITY EC=EXTRA COST

**STANDARD FEATURES** ONE SAW BLADE, OPERATION AND SAFETY MANUAL, SAFETY WALL POSTER, END CUT SAFETY PUSHER PLATE.

**SWITCH** TOGGLE, STANDARD, 2 HP RATED, PLACED CONVENIENTLY IN FRONT.

**HEAD AND DOOR** ALUMINUM, ENTIRE ASSEMBLY REMOVABLE.

**BASE STRUCTURE** STEEL PLATE, WELDED POWDER COATED.

**BLADE STANDARD** HARD TOOTH .020 INCH (.4 MM) THICK, FOUR TEETH PER INCH, 5/8 INCH (16 MM) WIDE, 78" (1981 MM) LONG, ONE SUPPLIED WITH EACH SAW.

**BLADE SPEED** 3000 FEET (914 M) PER MINUTE APPROXIMATE, FOR BOTH 50 AND 60 CYCLE OPERATION.

**BLADE GUIDE** UPPER AND LOWER BLADE BACKUP GUIDE ASSEMBLIES, REMOVABLE WITH LONG LIFE CARBIDE BACKUP INSERTS.

**BLADE TENSION** RATCHET ARM AND CAM AGAINST POUND TESTED SPRING AND TENSION SPRING GAUGE.

**BLADE WHEELS** 10" (25.4 CM) CAST IRON, CHROME NICKEL PLATING, UPPER WHEEL ASSEMBLY LIFTS OUT.

**BEARINGS** HEAVY DUTY TAPERED ROLLER BEARINGS IN UPPER WHEEL AND LOWER BEARING HOUSINGS.

**CATCH PAN** POLY, EXTRA DEEP, ROUNDED CORNERS, SEALED OFF FROM OTHER PARTS OF BASE, ACCESSIBLE THROUGH BASE HINGED DOOR.

**CLEANING UNIT** LONG LIFE CARBIDE GUIDES, STEEL SAW CLEANERS, REMOVABLE AS A UNIT FOR EASY CLEANING, (ASSEMBLY ALSO ADJUSTABLE AS A UNIT).

**DRIVE SYSTEM** NON-SLIP SILENT V-BELT, TENSION ADJUSTABLE.

**LEGS** STRAIGHT, NON ADJUSTABLE.

**MEAT CARRIAGE** STAINLESS STEEL WITH NYLON GUIDES AND STEEL BEARINGS.

**MEAT GAUGE PLATE** STAINLESS STEEL FACED, ADJUSTABLE FROM 1/16" (1.59 MM) TO 6-1/2" (165 MM), LOCKS IN POSITION, CAN BE THROWN OUT OF GEAR, ENTIRE ASSEMBLY REMOVABLE FOR CLEANING.

**MOTOR COMPARTMENT** SEALED OFF FROM MEAT CONTACT AREAS, EASILY ACCESSIBLE THROUGH REMOVABLE PANEL DOOR.

**PLATTER** ALL STAINLESS STEEL, HELD IN PLACE WITH TWO PUSH PULL HOLD DOWN STAINLESS STEEL RODS.

**SAFETY END CUT PUSHER PLATE** STANDARD, REMOVABLE.

**OPTIONS (EC)** POWER CORD AND PLUG, TOTALLY ENCLOSED MOTOR, WATERTIGHT MAGNETIC SWITCH WITH THERMAL OVERLOAD AND UNDER VOLTAGE PROTECTION, NSF CERTIFICATION.

**CERTIFICATION** C.S.A. 115-60-1, U.L. NOTE: IF NSF IS REQUIRED, MUST SPECIFY, EXTRA COST FOR NSF REQUIREMENTS.

**WEIGHT** UNCRATED: 256 LBS. (116 KG) APPROXIMATE.  
 CRATED: 298 LBS. (135 KG) APPROXIMATE.

**DIMENSIONS**  
**CRATED** L = 32" (81.3 CM), W = 40" (101.6 CM), H = 38-1/2" (97.8 CM).

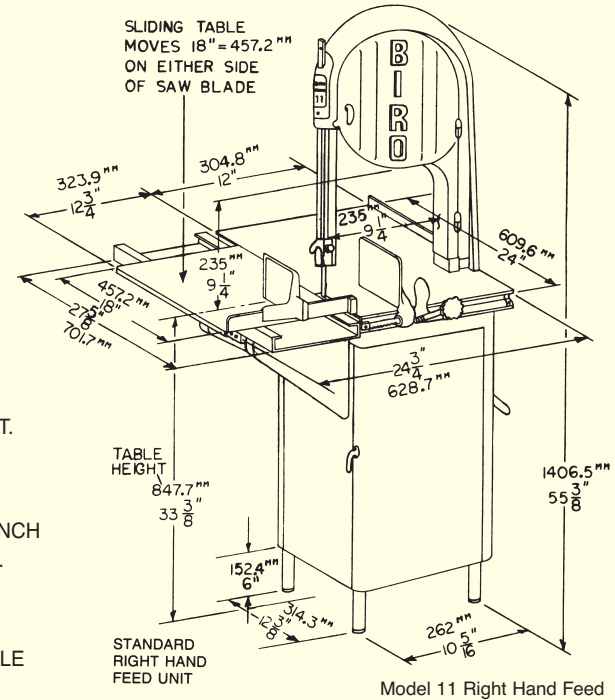

[www.thescaleshop.net](http://www.thescaleshop.net)

1-888-844-2031