

HEAT SEAL

SHRINK PACKAGING SYSTEMS

MODEL HS-1515

CONSOLE L SEALER

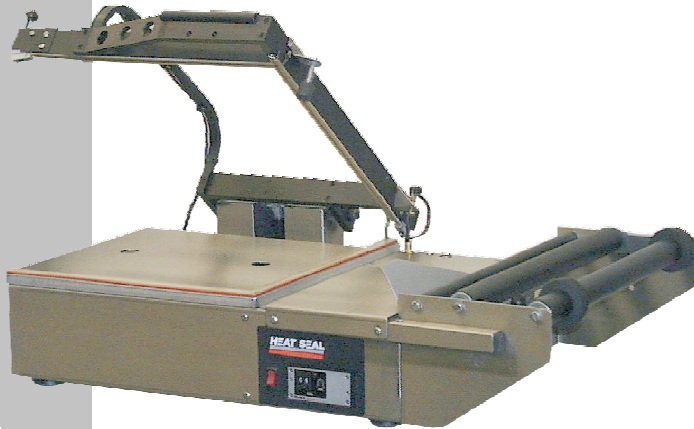

Shown As: HS-1515 Stainless Steel

**PROVIDES STRONG, CONSISTENT
SEALS WITH ALL TYPES
OF CENTERFOLDED FILM**

CAN BE SHIPPED UPS

Features of the HS-1515 Table Top L Sealer

- Standard 115 Volt Power Supply With Ground Fault Indicator
- 15" By 15" Sealing Area
- Temperature Compensating Solid State Seal Controller
- Quick Change Sealing Wire Tension Assembly
- Heavy Duty Seal Head Design
- High Quality Sealing Pad Design
- U.L. Listed Control Panel (File No. E146586)
- Highly Portable, Easily Moved
- Adjustable Height Wrapping Platform
- Heavy Gauge Steel Construction
- USDA Approved Stainless Steel Model Available (HS-1515S)

TWO YEAR WARRANTY

STANDARD DUTY SERIES

Machine Specifications

Film Capacity	17" (44 cm)
L-Bar Area	15" W, 15" L (38 W, 38 L cm)
Overall Dimensions	21" W, 29" L, 22" H (53 W, 74 L, 56 H cm)
Power Requirements	115V, 15 amp Single Circuit With Ground
Weight	55 lbs (25 kg) (Net w/Most Popular Options)

TWO YEAR WARRANTY

Machine Footprint

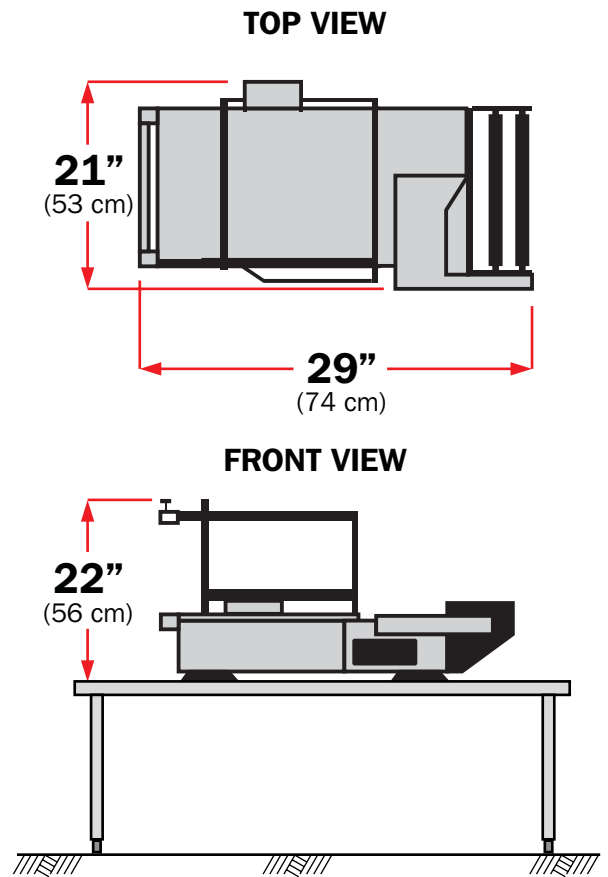

Machine Options

- Perforating Roller (Adjustable)
- Heated Hole Punch
- Film Separator Rod (For 6" Film Opening)
- Single Magnet Hold Down With Dwell
- 15" By 19" Seal Area (Factory Installed Only)
- Spare Parts Kit
- Export Wiring
- Stainless Steel Construction
- Special Paint Color



www.thescaleshop.net

1-888-844-2031

MODEL HS-1515 STANDARD DUTY