

# HEAT SEAL

®

## SHRINK PACKAGING SYSTEMS

### MODEL HS-115

#### COMBINATION SHRINK SYSTEM



Shown As: HS-115 With Optional Perforating Roller, Magnetic Hold Downs, Power Take Away Conveyor and Console Leg Kit

**OUR MOST POPULAR,  
DEPENDABLE, COMBINATION  
L SEALER/SHRINK TUNNEL**

#### Features of the HS-115 Combination System

- Standard 115 Volt Power Supply With GFI Protection
- Standard Microprocessor Acc-U-Seal Wire Temp Control
- U.L. Listed Control Panel (File No. E146586)
- Large 15" Wide By 20" Long Seal Area
- Heavy Duty Seal Head Design With Film Clamps
- Special High Quality Silicone Sealing Pad
- Quick Change Sealing Wire Tension Assembly
- Film Perforator
- Adjustable Height Wrapping Platform
- High Velocity Turbo Tunnel Design
- 6" High By 15" Wide Tunnel Opening (8" High Optional)
- 2,500 Watt Tunnel
- High Quality Calrod Heating Element
- Heavy Duty, High Temperature Blower Motor
- Adjustable Heat Tunnel Conveyor Belt For Bottom Shrink Control
- Heat Sensitive Cut-Off Switch
- Automatic Cool Down Extends Heating Element Life
- Heavy Gauge Steel Construction
- Stainless Steel Model Available
- Shipped Set Up And Ready To Use

## TWO YEAR WARRANTY

STANDARD DUTY SYSTEMS

## Machine Specifications

<b>Film Capacity</b>	<b>17" Wide (43 cm)</b>
<b>L Bar Seal Area</b>	<b>15" W, 20" L (38 W, 51 L cm)</b>
<b>Inside Tunnel Dimensions</b>	<b>6" H, 14 1/2" W, 20" L (15 H, 37 W, 53 L cm)</b>
<b>Overall Dimensions (w/Leg Kit)</b>	<b>49" H, 23" W, 84" L (15 H, 37 W, 213 L cm)</b>
<b>Working Height</b>	<b>35" (89 cm)</b>
<b>Power Requirement</b>	<b>115 Volts, 20 Amps Single Circuit w/Ground</b>
<b>Wattage</b>	<b>2,000 Watts: Tunnel 500 Watts: Conveyor Belt</b>
<b>Conveyor Speed (Tunnel)</b>	<b>0-20 Feet Per Minute</b>
<b>Weight (Net)</b>	<b>350 lbs. (159 kg)</b>

## Machine Footprint

TOP VIEW

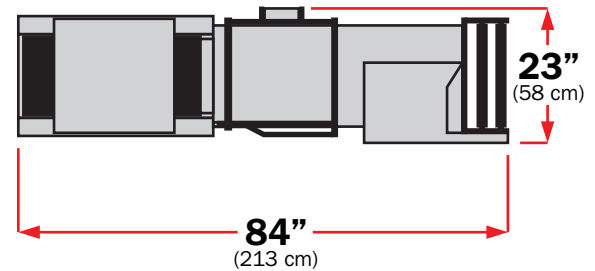

FRONT VIEW

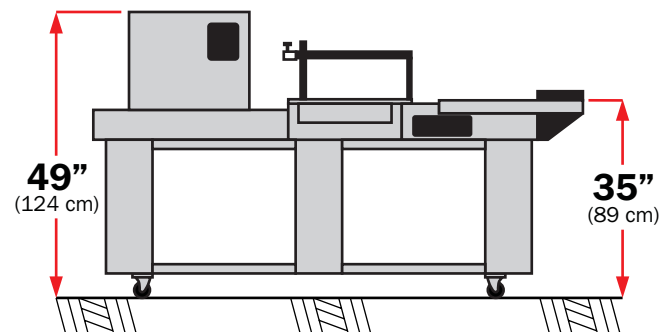

**TWO YEAR WARRANTY**

## Machine Options

- Perforating Roller (Adjustable)
- Heated Hole Punch
- Magnetic Hold Down With Dwell (Single or Double Magnet)
- 8" High Tunnel Opening (Factory Installed)
- Digital Tunnel Temperature Control
- Console Leg Kit With 3" Casters (Painted or Stainless)
- 5" Casters
- 6" Film Separator Rod
- Dual Film Rack
- Gravity Discharge Conveyor
- Power Take Away Conveyor (Silicone Belt)
- Posi-Trac Power Take Away
- Pre-Wired Power Take Away Ready
- Export Wire: 220 Volts
- Stainless Steel Construction
- Spare Parts Kit
- GTC-180/GTC-90 Gravity Turn Around Conveyors
- Powered Accumulator Tubs



[www.thescaleshop.net](http://www.thescaleshop.net)

1-888-844-2031