



INDUSTRIAL EQUIPMENT



SHIPMATE
SKIN PACKAGING MACHINE

PLC CONTROLLER SYSTEM

**SKINS ALL TYPES OF
PRODUCTS**

Features Available On The Shipmate Skin Machine

- **Stationary Oven With Safety Guard For Faster Cycling**
- **Patented Spirad® Instant Heater Elements**
- **Variable Speed Turbine Vacuum System**
- **Adjustable Pre-Heat, Heat And Cool Package Time Functions**
- **Spindle Film Roll Holder**
- **Adjustable Oven Height**
- **Pneumatic Film Frame Drive w/Independently Adjustable Up And Down Speeds**
- **Positive Displacement Vacuum System Available**
- **Shipped Set Up And Ready To Use**

ONE YEAR WARRANTY

Machine Specifications

Platen Size	18" W, 24" L (46 W, 61 L cm)
Platen Clearance	Adjustable 6"-18" (15-46 cm)
Platen Height	40" (102 cm)
Film Capacity	20" W, 9" OD, 3" ID (51 W, 23 OD, 7.5 ID cm)
Overall Dimensions	43" W, 39" D, 60" H (109 W, 99 D, 152 H cm)
Power Requirements	208 Volts, 41 Amps Single Phase
Air	1 cfm @ 80 psi
Vacuum (A)	Hivac Turbine 96 cfm, 6.5" Hg.
Vacuum (B)	Turbine plus 1/4 HP Pos. Disp. Pump, 21 Gal. Tank, 25" Hg.
Weight (A)	500 lbs. (227 kg)
Weight (B)	575 lbs. (260 kg)

ONE YEAR WARRANTY

Machine Options

- Spare Parts Kit
- Transformer For 440-480 Volts
- Energy Miser Film Temp Sensing
- Electro-Pulse Film Cutoff
- Special Size Frame Insert And Platen
- Automatic Blow Off For Vacuum System Forming
- 6 Foot Infeed/Outfeed Freestanding Table (Also With Carton Rack)
- 2 Foot Infeed/Outfeed Bolt On Wing
- Positive Displacement Vacuum System
- Automatic Film Frame

Machine Footprint

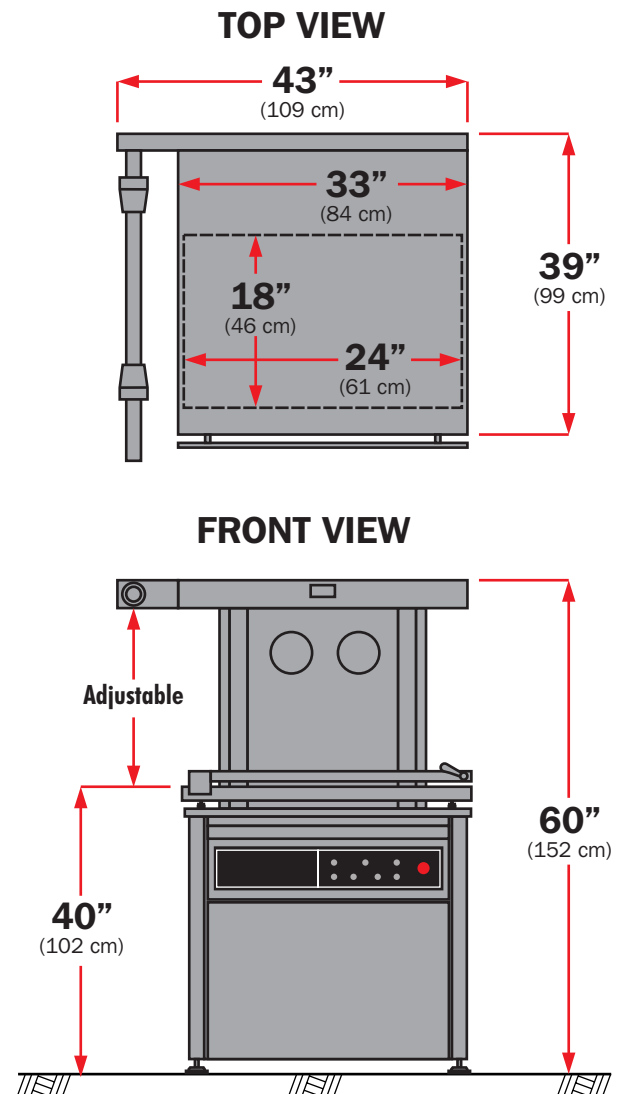

NOTE Recommended Films:
 3-20 Mil Polyethylene, Surlyn, Co-Polymers,
 PETG, Primacor and PVC

Recommended Board:
 Corrugated, Shipmate, Cartons, Boxboard
 and S.B.S.

Die Cutter: Rotocut or Rotomatic



www.thescaleshop.net

1-888-844-2031