

## Packaging Machinery



# Hurricane

# Hurricane



Examples of products

**Horizontal flow wrap packaging machine which produces closed wrappers with three sealed edges from a roll of heat-sealable wrapping material.**

**Packaging which is strong, attractive and perfect:** the special design of the forming tunnel, the optimum calender and roller device for film transfer and the position of the various component units combine to give a machine which wraps the product perfectly and produces seals which are wrinkle free and positioned correctly.

**High flexibility and quick format change:** Hurricane can package a vast range of regularly shaped, solid products from the food, stationery, chemical and pharmaceutical sectors. It is not necessary to change any mechanical part in order to change the set-up, this is done by using two handwheels which carry out immediate adjustments to the length of the package and the speed of the sealing crimpers.



COMPANY  
WITH QUALITY SYSTEM  
CERTIFIED BY DNV  
=ISO 9001/2000=

PFM S.p.A. (headquarters)  
via Pasubio, 49  
36036 Torrelbelvicino (VI) Italy



**Optional:**

- Date Printer.
- Photocell to register centre-printed wrapping material.
- Dual reel holder.
- Pre-heating of the first set of Fin Wheels: useful for speeds greater than 100 package/min.
- Two Up Sealing Crimper Jaws for use with smaller products and for higher speed.
- Shrink Version.

**In addition, for the Electronic version:**

- Driven by two brushless motors in electric axis for separate control of the longitudinal and transversal sealing units.
- Adjustment of the bag length by means of an alphanumeric keyboard.
- Automatic print centring in real time.

**Technical Specifications:**

- Conforms to EEC standards.
- 2M long in-feed belt with quick-release, interchangeable pushers.
- 2 hand wheels with numerical reference system for adjusting package length and crimper speed.
- Forming box with adjustable height and width for different sized products.
- 3 pairs of Fin Wheels.
- Self-centering reel holder with reel brake.
- 600mm long motorized discharge belt.



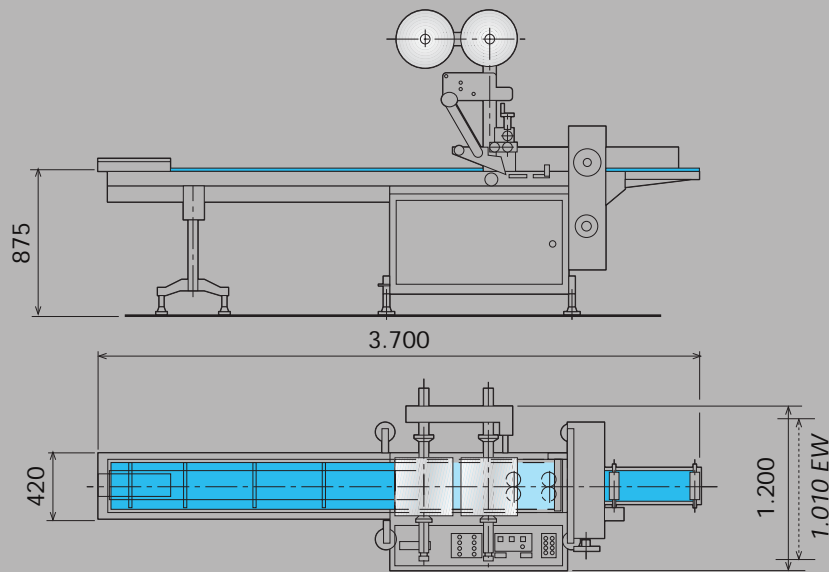

# Hurricane

## Technical Data:

	HURRICANE	HURRICANE EW
<b>Pack length:</b>	min 40, max 350 mm	min 40, max 350
<b>Pack width:</b>	min 5, max 220 mm	min 5, max 320 mm
<b>Pack height:</b>	up to 100 (standard version) 140 mm (special version)	up to 100 (standard version) 140 mm (special version)
<b>Reel width:</b>	max 500 mm	max 700 mm
<b>Reel diameter:</b>	max 350 mm	max 350 mm
<b>Width of sealing crimper jaws:</b>	250 mm	350 mm
<b>N° of up sealing crimpers jaws:</b>	1 - 2	1 - 2
<b>Mechanical speed:</b>	up to 100 cycles/min*	up to 100 cycles/min*
<b>Versions:</b>	mechanical	mechanical - electronic
<b>Wrapping material:</b>	PP (laminated or bonded), PE (Poly version) and shrink	PP (laminated or bonded), PE (Poly version) and shrink
<b>Weight:</b>	350 Kg	400 - 350 Kg
<b>Power consumption:</b>	3,5 Kw	3,5 - 5,5 Kw
<b>Power supply:</b>	380V 3phase + neutral + earth 50Hz	380V 3phase + neutral + earth 50Hz

\* Depending on product size wrapping material and number of crimpers.

The technical specifications stated are merely indicative and may vary according to the type and dimensions of the product, output required and type of wrapping material used.

Data should always be confirmed by PFM's technical department.

The final technical specifications calculated according to the above mentioned variables are only given in the official offer.

PFM reserves the right to make modifications without prior notice.



[www.thescaleshop.net](http://www.thescaleshop.net)

1-888-844-2031