



Known For Reliability For Over 89 Years

The Biro Model AFMG-52 is the ideal workhorse mixer grinder for large supermarket meat rooms and medium sized processors and HRI plants. Its 7.5 hp (5.6 kW) motor (or optional 10 hp, 7.5 kW motor) provide an output of up to 100 lbs. (45.5 kg) per minute to give you the productivity you need. The separate auger and mixer motors means there is no clutch to wear out or break, which means much lower maintenance costs and higher profits. The heavy duty roller chain auger drive with tapered roller bearings is separate from the mixer drive, to give maximum power to the auger and more efficiency. The heavy duty stainless steel 200 lb. (90.9 kg) hopper and frame resist corrosion and damage, even in an environment of harsh cleaners. Your mixer grinder lasts longer and gives you more return on your investment. Power, durability, and low maintenance help the Biro Model AFMG-52 Mixer Grinder work harder so you don't have to.



STANDARD, NO INLET

AFMG-52



*Stands alone for quality
and value since 1921*

SPECIFICATIONS

MODEL AFMG-52 MIXER GRINDER.
CONSTRUCTION HEAVY DUTY STAINLESS STEEL HOPPER, LID, PADDLE, FRAME AND LEGS. CAST IRON HOT TIN DIPPED BOWL, RING AND AUGER, SIZE 52.

MOTORS

MOTOR	HP	KW	TYPE	VOLTS	AMPS	CYCLE	PH	STATUS
AUGER	7.5	5.5	TEFC	208-230/460	24-22/11	60	3	STD
MIXER	1.75	1.3	TEFC	208-230/460	5.7-5.2/2.6	60	3	STD
AUGER	10	7.5	TEFC	208-230/460	31-28/14	60	3	EC
AUGER	7.5	5.5	TEFC	575	8.8	60	3	EC
MIXER	1.75	1.3	TEFC	575	2.4	60	3	EC
AUGER	10	7.5	TEFC	575	11	60	3	EC
AUGER	7.5	5.5	TEFC	220/380-415	22/12.7-12.4	50	3	STD
MIXER	1.75	1.3	TEFC	220/380-415	5.9/3.4-3.1	50	3	STD
AUGER	10	7.5	TEFC	220/380-415	28/16.2-14	50	3	EC

STD=Standard EC=Extra Cost TEFC=Totally Enclosed Fan Cooled

SWITCH WATERTIGHT MAGNETIC WITH THERMAL OVERLOAD AND UNDER VOLTAGE PROTECTION.

POWER CORD 12' 10-4 CORD WITH PLUG 7-1/2 HP, U.S., 12' 10-4 CORD NO PLUG 7-1/2 HP INTERNATIONAL, 12' 8-4 CORD WITH PLUG 10 HP U.S., 12' 8-4 CORD NO PLUG 10 HP INTERNATIONAL.

HOPPER CAPACITY HOPPER: 200 LBS (91 KG). A 400 LB. (182 KG) IS ALSO AVAILABLE.

GRINDING CAPACITY OUTPUT - UP TO 100 LBS (45.5 KG) PER MINUTE.

DRIVE SYSTEM AUGER: SINGLE REDUCTION (35 PITCH - 4 ROW) ROLLER CHAIN DRIVE WITH TAPERED ROLLER BEARINGS. MIXER: HEAVY DUTY COMBINATION GEAR MOTOR.

SAFETY MAGNETIC SAFETY INTERLOCK ON HOPPER LID.
STANDARD FEATURES TUB WITH NO SIDE INLET, STAINLESS STEEL 2ND GRIND PADDLE WITH CENTER ARMS, CASTERS, SPURT GUARD, EXTRA ROD FOR FRONT, LEFT OR RIGHT SIDE OPENING LID, POWER CORD (SEE ABOVE), RING WRENCH, BOWL NUT WRENCH, TWO SHEAR PINS WITH SCREWS, RECEPTACLE FOR ELECTRIC FOOTSWITCH, OPERATING AND SAFETY MANUAL.

OPTIONS (EC) ELECTRICAL OR PNEUMATIC FOOTSWITCH, SIZE 52 PLATE AND KNIFE, ACCESSORY CLEANING AND STORAGE RACK, EXTRA LONG STAINLESS STEEL LEGS (33"/838 MM TO 42"/1069 MM) FROM FLOOR TO BOWL CENTER, LEFT HAND 35 DEGREE SIDE INLET, LEFT OR RIGHT 90 DEGREE STRAIGHT SIDE INLET, CONNECTIONS FOR TANDEM OPERATIONS, 10 HP (7.5 KW) AUGER MOTOR, STAINLESS STEEL BOWL, RING AND AUGER (ENTERPRISE OR UNGER).

OPTIONS (NC) 35 DEGREE RIGHT HAND INLET (CALL FACTORY).

CERTIFICATION U.S.D.A., U.L., N.S.F., C.S.A., C.F.I.A.

WEIGHT UNCRATED: 745 LBS. (338 KG) APPROXIMATE.

CRATED: 855 LBS. (387 KG) APPROXIMATE.

DIMENSIONS
CRATED L=53" (134.6 CM), W=38" (96.5 CM), H=66" (167.6 CM).

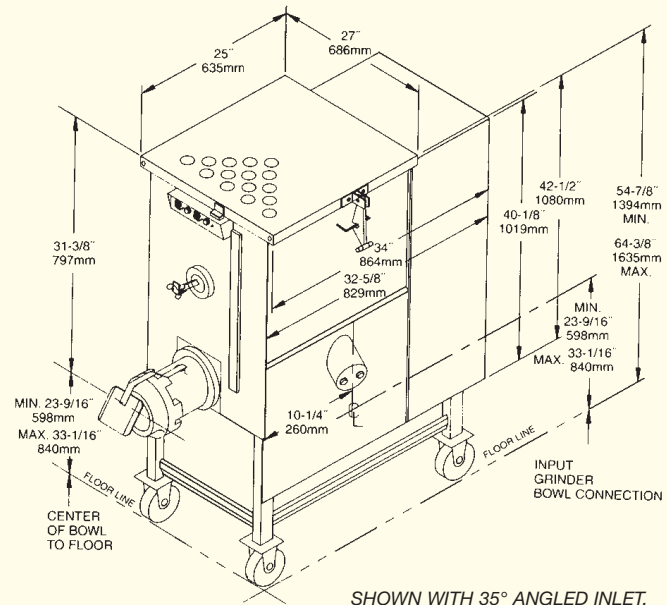

www.thescaleshop.net

1-888-844-2031