

# BIRO®

## *Our Equipment Works Harder So You Don't Have To*

The 5 hp (3 Kw) motor provides all the power you need to break pork, lamb, veal, or beef all day in a high volume production operation. Heavy duty, stainless steel construction helps the Model 55 hold up under the harshest conditions with minimum maintenance. With the standard front moving carriage and meat gauge plate and 20" H (508 mm) by 21" D (533 mm) cutting clearance, you can use the same saw to produce retail cuts or split loins and break quarters, which makes the Model 55 unmatched for versatility. Superior Biro engineering means you'll have a saw that's built to last. Over the life of the saw you'll get more for your money. As with all Biro products, if you need a particular modification to fit your application let us know. We'll try to build it for you - something only Biro does.



*Safety Pusher Plate  
not mounted*

# 55

MEAT PACKERS WHO KNOW USE BIRO!



*Stands alone for quality  
and value since 1921*

## SPECIFICATIONS

**MODEL** 55 POWER CUTTER (BREAKING SAW - 22")  
**CONSTRUCTION** HEAVY DUTY STAINLESS STEEL 8 GAUGE (4.2 MM) BASE AND FIXED HEAD.  
**MOTORS**

HP	TYPE	VOLTS	AMPS	HERTZ	PHASE	CODE
5	TEFC	208/230	15/13.2	60	3	STD
5	TEFC	440/460	8/6.6	60	3	OPNC
5	TEFC	220/380/415	14/8.1	50	3	OPNC
5	TEFC	550/575	5.9	60	3	EC

TEFC= TOTALLY ENCLOSED FAN COOLED    STD=STANDARD  
 OP=OPTIONAL    NC=NO CHARGE    EC=EXTRA COST

**STANDARD FEATURES**

TWO SAW BLADES, OPERATION AND SAFETY MANUAL, SAFETY WALL POSTER, END CUT SAFETY PUSHER PLATE.

**SWITCH**

WATERTIGHT MAGNETIC WITH THERMAL OVER LOAD AND UNDER VOLTAGE PROTECTION.

**HEAD AND DOOR**

STAINLESS STEEL, FIXED.

**BASE STRUCTURE**

STAINLESS STEEL.

**BLADE STANDARD**

HARD TOOTH, THREE TEETH PER INCH (8.5 MM BETWEEN TEETH), 164-1/2" (4178.3 MM) LONG X 3/4" (19 MM) WIDE X .022" (0.56 MM) THICK (TWO SUPPLIED WITH EACH SAW).

**BLADE SPEED**

3880 FEET (1180 M) PER MINUTE.

**BLADE GUIDE**

UPPER AND LOWER BLADE BACKUP GUIDE ASSEMBLIES, REMOVABLE WITH LONG LIFE CARBIDE BACKUP INSERTS.

**BLADE TENSION**

FACTORY PRESET SPRING, SCREW HANDLE ASSEMBLY.

**BLADE WHEELS**

22" (55.8 CM) CAST IRON, CHROME NICKEL PLATING, UPPER WHEEL ASSEMBLY LIFTS OUT.

**BEARINGS**

HEAVY DUTY TAPERED ROLLER BEARINGS USED IN UPPER WHEEL AND LOWER BEARING HOUSINGS.

**CATCH PAN**

EXTRA DEEP, STAINLESS STEEL SEALED OFF FROM OTHER PARTS OF BASE, ACCESSIBLE THROUGH BASE HINGED DOOR.

**CLEANING UNIT**

STAINLESS STEEL BODY, LONG LIFE-CARBIDE GUIDES, STEEL SAW CLEANERS, REMOVABLE AS A UNIT FOR EASY CLEANING, (ASSEMBLY ALSO ADJUSTABLE AS A UNIT).

**DRIVE SYSTEM**

NON SLIP SILENT V-BELT, TENSION ADJUSTABLE.

**LEGS**

STAINLESS STEEL LEG WITH DISCS, ADJUSTABLE.

**MEAT CARRIAGE**

STAINLESS STEEL 10 BEARING E-Z FLOW.

**MEAT GAUGE PLATE**

STAINLESS STEEL FACED, ADJUSTABLE FROM 1/16" (1.59 MM) TO 6-1/2" (165 MM) LOCKS IN POSITION, CAN BE THROWN OUT OF GEAR, ENTIRE ASSEMBLY REMOVABLE FOR CLEANING.

**MOTOR COMPARTMENT**

SEALED OFF FROM MEAT CONTACT AREAS, EASILY ADJUSTABLE THROUGH REMOVABLE PANEL DOOR.

**PLATTER**

SPLIT, TWO PIECE STAINLESS STEEL, HELD IN PLACE WITH PUSH PULL HOLD DOWN STAINLESS STEEL ROD AND TWO KNOBS FOR EASY REMOVAL.

**SAFETY END CUT**

STANDARD, REMOVABLE.

**PUSHER PLATE**

POWER CORD AND PLUG, FRONT TABLE EXTENSION, STATIONARY FRONT TABLE, LEFT HAND OPERATION, ROLLER TOP AND DOUBLE ROLLING TABLES, STAINLESS STEEL WHEELS.

**OPTIONS (EC)**

**OPTIONS (NC)**

4200 FEET (1280 M), 5000 FEET (2273 M) PER MINUTE. BLADE SPEED.

**CERTIFICATION**

U.S.D.A.

**WEIGHT**

UNCRATED: 750 LBS. (340 KG) APPROXIMATE.  
 CRATED: 1175 LBS. (498 KG) APPROXIMATE.

**DIMENSIONS**

**CRATED**

L=54" (137.2 CM), W=62" (157.5 CM), H=86" (218.4 CM).

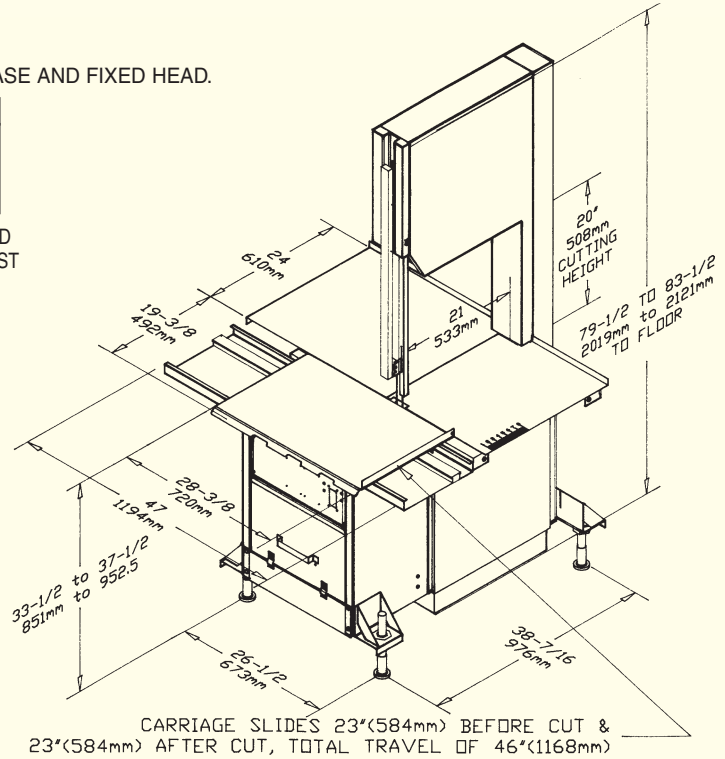

[www.thescaleshop.net](http://www.thescaleshop.net)

1-888-844-2031