



Known For Reliability For Over 87 Years

The Biro 1433/1433FH Meat Saw is a compact production saw that's perfect for today's scaled down meat room.

It's 3 hp, totally enclosed motor and 3550 feet per minute blade speed (higher speeds available at no charge) provide you with the power you need. Biro's exclusive EZ-Flow meat carriage helps reduce operator fatigue and increase productivity. It features a watertight magnetic starter with thermal overload protection, removable lower wheel, and double V belt and pulley drive system. Both incorporate the superior design and engineering you've come to expect from Biro, which means you'll get years of use, low maintenance, and lower overall cost of ownership.



1433



1433FH
FIXED HEAD

1433 / 1433FH



*Stands alone for quality
and value since 1921*

SPECIFICATIONS

MODEL 1433 POWER CUTTER (MOVABLE HEAD - 14").
1433 FH POWER CUTTER (FIXED HEAD - 14").
CONSTRUCTION HEAVY DUTY STAINLESS STEEL BASE, LEGS, HEAD AND DOOR STRUCTURE.

HP	KW	TYPE	VOLTS	AMPS	CYCLE	PH	STATUS
3	2.2	TE	208/220/440	6.4/6/3	60	3	STD
3	2.2	TE	220/380/415	6/4/3	50	3	STD
2	1.5	OP-HH	115/208/230	20/11/10	60	1	STD
2	1.5	OP-HH	220	9	50	1	EC
3	2.2	TE	200	6	60	3	EC
2	1.5	TE	550	2-8	60	3	EC

TE = Totally Enclosed OP = Open HH = High Humidity STD = Standard EC = Extra Cost

STANDARD FEATURES

TWO SAW BLADES, OPERATION AND SAFETY MANUAL, SAFETY WALL POSTER, END CUT SAFETY PUSHER PLATE.

SWITCH

WATERTIGHT MAGNETIC WITH THERMAL OVERLOAD AND UNDER VOLTAGE PROTECTION.

**HEAD AND DOOR
BASE STRUCTURE**

STAINLESS STEEL.
STAINLESS STEEL.

BLADE STANDARD

HARD TOOTH .022 INCH (.5 MM) THICK, THREE TEETH PER INCH (8.5 MM BETWEEN TEETH), 5/8 INCH (16 MM) WIDE, 108 INCHES (2743 MM) LONG (TWO SUPPLIED WITH EACH SAW).

BLADE SPEED

3600 FEET (1097 M) PER MINUTE. APPROX. 50/60 CYCLE.

BLADE GUIDE

UPPER AND LOWER BLADE BACKUP GUIDE ASSEMBLIES, REMOVABLE WITH LONG LIFE CARBIDE BACKUP INSERTS.

BLADE TENSION

1433 - RATCHET ARM AND CAM AGAINST TENSION SPRING GAUGE
1433FH - FACTORY PRESET SPRING, SCREW HANDLE ASSEMBLY.

BLADE WHEELS

14" (35.5 CM) CAST IRON, CHROME NICKEL PLATING, UPPER WHEEL ASSEMBLY LIFTS OUT.

BEARINGS

HEAVY DUTY TAPERED ROLLER BEARINGS USED IN UPPER WHEEL AND LOWER BEARING HOUSINGS.

CATCH PAN

POLY, EXTRA DEEP, ROUNDED CORNERS, PAN SEALED OFF FROM OTHER PARTS OF BASE, ACCESSIBLE THROUGH BASE HINGED DOOR.

CLEANING UNIT

STAINLESS STEEL BODY, LONG-LIFE CARBIDE GUIDES, STEEL SAW CLEANERS, REMOVABLE AS A UNIT FOR EASY CLEANING (ASSEMBLY ALSO ADJUSTABLE AS A UNIT).

DRIVE SYSTEM

NON SLIP SILENT V-BELT, TENSION ADJUSTABLE.

LEGS

STAINLESS STEEL LEG BOLT LEVELERS.

MEAT CARRIAGE

STAINLESS STEEL 8 BEARING E-Z FLOW.

MEAT GAUGE PLATE

STAINLESS STEEL FACED, ADJUSTABLE FROM 1/16" (1.59 MM) TO 6-1/2" (165 MM) LOCKS IN POSITION, CAN BE THROWN OUT OF GEAR, ENTIRE ASSEMBLY REMOVABLE FOR CLEANING.

MOTOR COMPARTMENT

SEALED OFF FROM MEAT CONTACT AREAS, EASILY ACCESSIBLE THROUGH REMOVABLE PANEL DOOR.

PLATTER

ALL STAINLESS STEEL, HELD IN PLACE WITH TWO PUSH PULL HOLD DOWN STAINLESS STEEL RODS.

**SAFETY END CUT
PUSHER PLATE**

STANDARD, REMOVABLE.

OPTIONS (EC)

POWER CORD AND PLUG, FRONT TABLE EXTENSION.
STATIONARY FRONT TABLE, DOUBLE FLANGE WHEELS,
SPLIT REAR PLATTER, LONGER MEAT GAUGE PLATES.

OPTIONS (NC)

4200 FEET (1280 M) PER MINUTE BLADE SPEED.

CERTIFICATION

U.S.D.A., U.L., N.S.F.

WEIGHT

1433 UNCRATED: 374 LBS. (169.6 KG) APPROXIMATE.
CRATED: 478 LBS. (217 KG) APPROXIMATE.
1433FH UNCRATED: 385 LBS. (174.6 KG) APPROXIMATE.
CRATED: 489 LBS. (222 KG) APPROXIMATE.

DIMENSIONS

CRATED

1433: L=48" (121.9 CM), W=37" (93.9 CM), H=38" (96.5 CM).
1433FH: L=38" (96.5 CM), W=50" (127 CM), H=77" (195.6 CM).

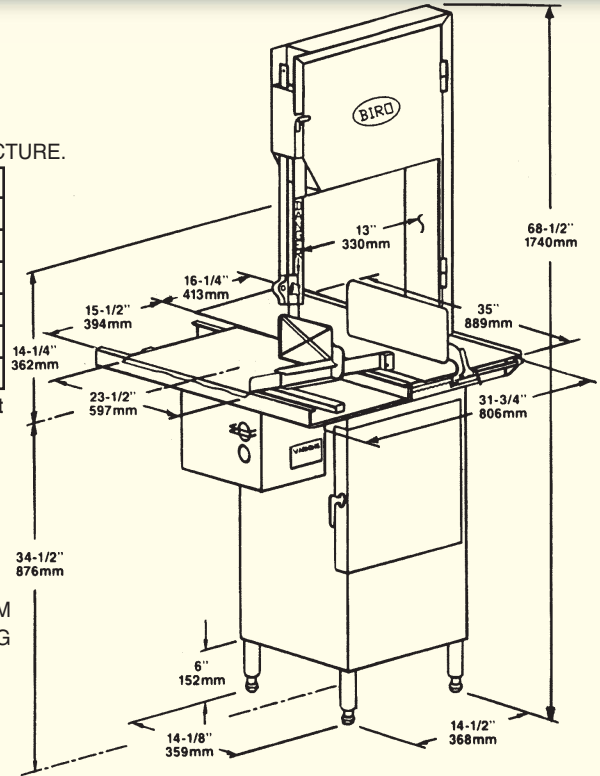

www.thescaleshop.net

1-888-844-2031