

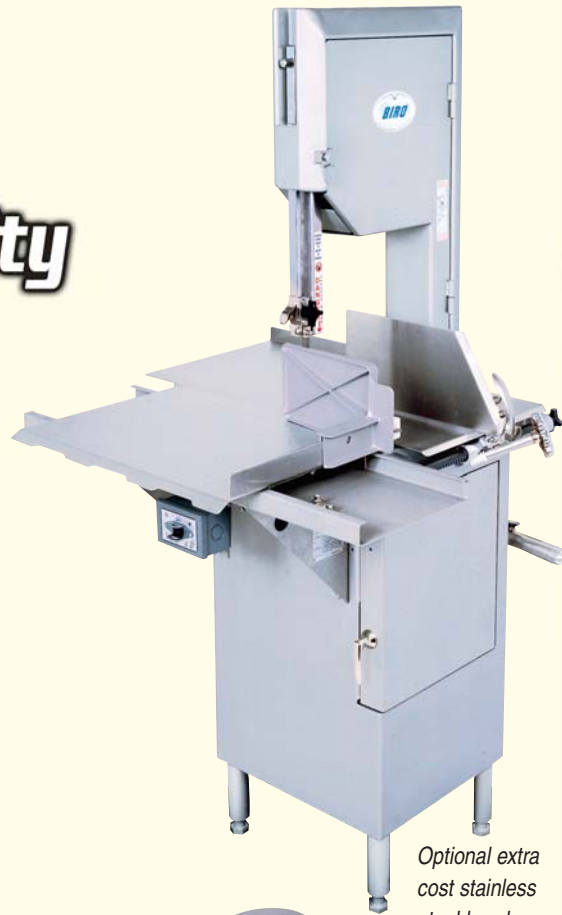

## ***Known For Reliability For Over 87 Years***

The Biro Model 22SS Meat Saw is a smaller saw that's ideal for small meat shops, grocery service meat counters, and fish shops. Its 1½ hp motor has the power and size to meet your custom meat and fish cutting needs. The unitized welded stainless steel base and cast aluminum head resist corrosion and ensure long equipment life. The upper wheel and lower wheel drive assemblies utilize tapered roller bearings for smooth operation and low maintenance. It's separated, enclosed motor compartment helps protect the motor against moisture and corrosion. The optional stainless steel head assembly and optional watertight magnetic switch assembly turn the 22SS into a perfect production saw for fish cutting operations. Our 22SS incorporates the superior design and engineering you've come to expect from Biro, which means you'll get years of use, low maintenance, and lower overall cost of ownership.



*Optional extra cost stainless steel head (above)*

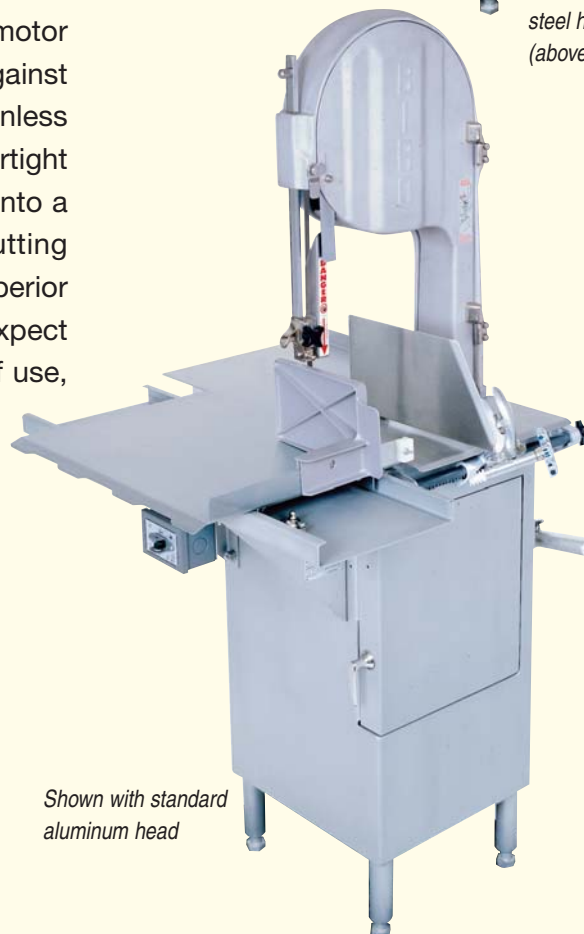

*Shown with standard aluminum head*

# 22SS



*Stands alone for quality  
and value since 1921*

## SPECIFICATIONS

**MODEL**  
**CONSTRUCTION**

22SS POWER CUTTER (12").  
STAINLESS STEEL BASE, ALUMINUM HEAD STANDARD,  
STAINLESS STEEL HEAD STRUCTURE EC.

**MOTORS**

HP	KW	TYPE	VOLTS	AMPS	CYCLE	PH	STATUS
1½	1.1	HH	115/208-230	21/11/10.5	60	1	STD
1½	1.1	HH	208-220/440	6-5.6/2.8	60	3	STD
1½	1.1	HH	115/208-230	20/10-11	50	1	EC
1½	1.1	TE	115/208-230	20/10-11	60	1	EC
1½	1.1	TE	208-220/440	6-5.6/2.8	60	3	EC
1½	1.1	HH	220/380-415	6/3.6-3.2	50	3	STD
1½	1.1	TE	220/380-415	6/3.6-3.2	50	3	EC
2	1.5	OP	220/440	5.6/2.8	60	3	EC
2	1.5	OP	220/380-415	6/3.6-3.2	50	3	EC

TE= TOTALLY ENCLOSED      STD=STANDARD  
HH= HIGH HUMIDITY      EC=EXTRA COST

**STANDARD FEATURES**

TWO SAW BLADES, OPERATION AND SAFETY MANUAL, SAFETY WALL POSTER, END CUT SAFETY PUSHER PLATE.

**SWITCH**

TOGGLE, STANDARD, 2 HP RATED, PLACED CONVENIENTLY IN FRONT.

**HEAD AND DOOR**

ALUMINUM, ENTIRE ASSEMBLY REMOVABLE.

**BASE STRUCTURE**

STAINLESS STEEL.

**BLADE STANDARD**

HARD TOOTH, FOUR TEETH PER INCH, 5/8" (16 MM) WIDE, .020 (.051 MM) THICK, 91" (2311 MM) LONG (TWO SUPPLIED WITH EACH SAW).

**BLADE SPEED**

3000 FEET (914 M) PER MINUTE APPROX. 50/60 CYCLE OPERATION.

**BLADE GUIDE**

UPPER AND LOWER BLADE BACKUP GUIDE ASSEMBLIES, REMOVABLE WITH LONG LIFE CARBIDE BACKUP INSERTS.

**BLADE TENSION**

RATCHET ARM AND CAM AGAINST TENSION SPRING GAUGE.

**BLADE WHEELS**

12" (30.4 CM) CAST IRON, CHROME NICKEL PLATING, UPPER WHEEL ASSEMBLY LIFTS OUT.

**BEARINGS**

HEAVY DUTY TAPERED ROLLER BEARINGS USED IN UPPER WHEEL AND LOWER BEARING HOUSINGS.

**CATCH PAN**

POLY, EXTRA DEEP, ROUNDED CORNERS, PAN SEALED OFF FROM OTHER PARTS OF BASE, ACCESSIBLE THROUGH BASE HINGED DOOR.

**CLEANING UNIT**

STAINLESS STEEL BODY, LONG-LIFE CARBIDE GUIDES, STEEL SAW CLEANERS, REMOVABLE AS A UNIT FOR EASY CLEANING.

**DRIVE SYSTEM**

NON SLIP SILENT V-BELT, TENSION ADJUSTABLE.

**LEGS**

STAINLESS STEEL LEG BOLT LEVELERS.

**MEAT CARRIAGE**

STAINLESS STEEL WITH NYLON GUIDES AND STEEL BEARINGS, REMOVABLE THUMB GUARD.

**MEAT GAUGE PLATE**

STAINLESS STEEL FACED, ADJUSTABLE FROM 1/16" (1.59 MM) TO 6-1/2" (165 MM) LOCKS IN POSITION, CAN BE THROWN OUT OF GEAR, ENTIRE ASSEMBLY REMOVABLE FOR CLEANING.

**MOTOR COMPARTMENT**

SEALED OFF FROM MEAT CONTACT AREAS, EASILY ACCESSIBLE THROUGH REMOVABLE PANEL DOOR.

**PLATTER**

ALL STAINLESS STEEL, HELD IN PLACE WITH TWO PUSH PULL HOLD DOWN STAINLESS STEEL RODS.

**SAFETY END CUT**

STANDARD, REMOVABLE.

**PUSHER PLATE**

**OPTIONS (EC)**

POWER CORD AND PLUG, TOTALLY ENCLOSED MOTOR, WATERTIGHT MAGNETIC SWITCH WITH THERMAL OVERLOAD AND UNDER VOLTAGE PROTECTION, STAINLESS STEEL HEAD, GENERAL PURPOSE MANUAL PUSH BUTTON SWITCH, 2HP MOTOR.

**OPTIONS (NC)**

NONE AT NO CHARGE.

**CERTIFICATION**

U.L., N.S.F., U.S.D.A., C.S.A., C.F.I.A., EC (WITH MODIFICATIONS).

**WEIGHT**

UNCRATED: 308 LBS. (140 KG) APPROXIMATE.  
CRATED: 336 LBS. (152 KG) APPROXIMATE.  
STAINLESS STEEL HEAD, ADD 20 LBS. (9 KG).

**DIMENSIONS**

**CRATED**

L=32" (81.3 CM), W=40" (101.6 CM), H=38-1/2" (97.8 CM).

## MODEL 22SS STANDARD RIGHT HAND FEED UNIT

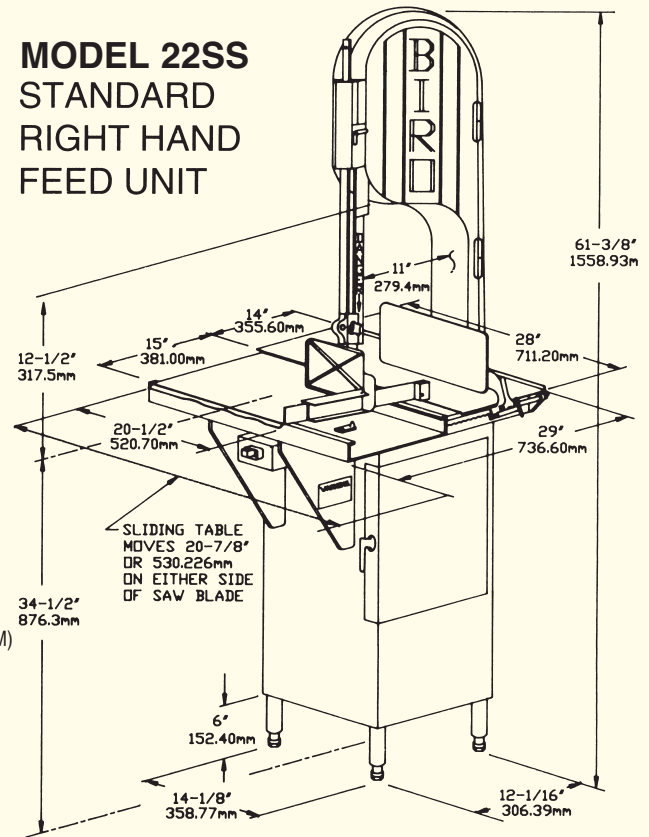

[www.thescaleshop.net](http://www.thescaleshop.net)

1-888-844-2031