

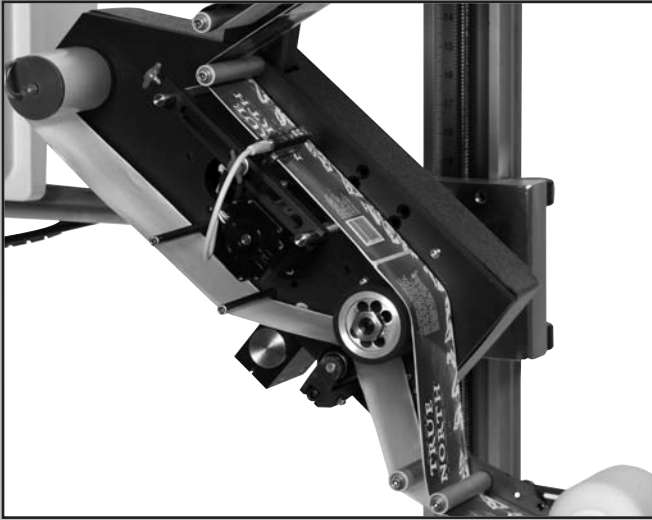

**SCALES**HOP  
customized weighing and packaging systems

# LABEL SYSTEMS





## TECHNICAL DATA

---

- **Label Width**  
80 mm 120 mm 150 mm 200 mm  
(3.15") (4.72") (5.9") (7.87")
- **Dispensing Speed**  
LS550 – 0-2000 inches per minute
- **Label Peel Tip Accuracy**  
LS550 + or - 1/32" (0.75 mm)
- **Construction Materials**  
Anodized Aluminum and Stainless Steel
- **Drive and Controls**  
Stepper Motor Drive and Controls  
Touchscreen HMI Colour  
Encoder Ready/Label Counter/Batch Counter
- **Options**  
Encoder for Speed Matching  
Broken Web Detection (Beacon)  
Low Label Detection (Beacon)
- **Sensing**  
Product and Label Sensing  
*Other sensor options available.*

## TYPICAL APPLICATIONS

---

- Top Labelling
- Side Panel Labelling  
(with one or two applicators)
- Wrap Around Labelling

## OPTIONAL ACCESSORIES

---

- Thermal Transfer Coder
- Missing Label Detectors
- Broken Web Detection
- Speed Matching
- Label Counter



[www.thescaleshop.net](http://www.thescaleshop.net)

1-888-844-2031