

# Model 65040

Sensortronics

## Double-Ended Shear Beam Load Cell

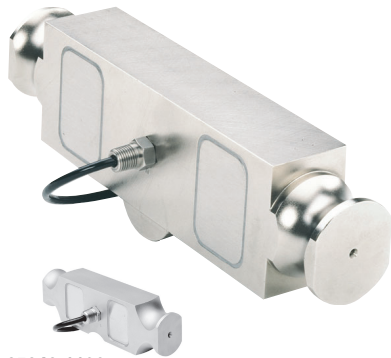

65040-1122



Factory Mutual System  
Approved

### FEATURES

- Rated capacities of 25,000 to 125,000 pounds, 10 to 45 metric tons
- Center supported, external pivot loading
- Integral conduit adaptor
- Trade certified for NTEP Class III:10000 divisions and OIML R60 3000 divisions
- *Sensorgage™* sealed to IP67 standards
- Factory Mutual System Approved for Classes I, II, III; Divisions 1 and 2; Groups A through G. Also, non-incendive ratings (No barriers!).

### OPTIONAL FEATURES

- Stainless steel available as 65040W
- Internal pivot loading available as 65040-1122

### DESCRIPTION

The 65040 is a mid to high capacity nickel plated alloy steel, double ended shear beam load cell.

This product is designed for use in certified truck and rail scales and is available in capacities ranging from 25K to 125Klbs.

This load cell is rated intrinsically safe by the Factory Mutual System (FM); making it

suitable for use in potentially explosive environments. This load cell is certified for Legal For Trade applications by both American NTEP and International OIML standards.

### APPLICATIONS

- Truck scales
- Railroad track scales
- "Legal for Trade" tank, bin and hopper weighing

### OUTLINE DIMENSIONS in inches [mm]

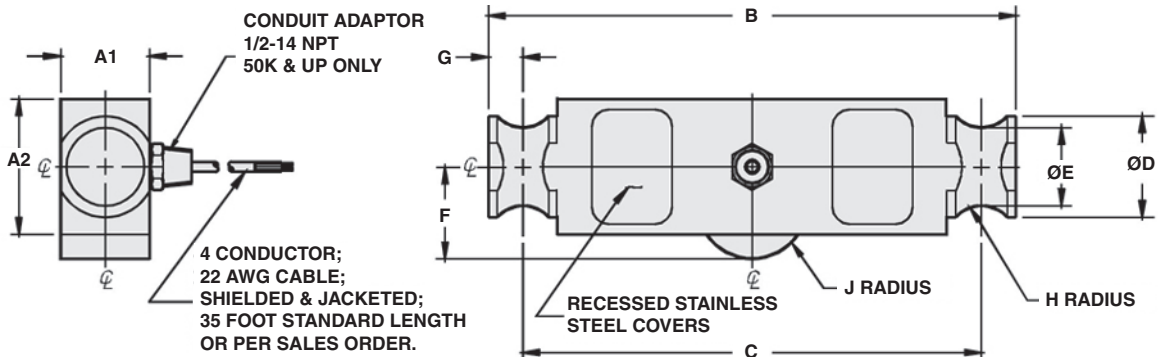

#### Wiring

+ Excitation	Red
- Excitation	Black
+ Output	Green
- Output	White

CAPACITY	A1	A2	B	C	D	E	F	G	H	J
25K - 40K	1.94	2.44	8.25	7.25	2.0	1.63	1.75	0.50	0.50	0.50
50K - 75K	1.94	2.94	11.50	10.00	2.2	1.70	2.00	0.75	0.75	1.00
100K - 125K	2.90	3.86	14.50	12.50	3.2	2.44	2.75	1.00	1.00	1.50
[10t]	[49.3]	[61.9]	[209.6]	[184.2]	[50.8]	[41.4]	[44.5]	[12.7]	[12.7]	[12.7]
[25 - 35t]	[49.3]	[74.7]	[292.1]	[254.0]	[55.9]	[43.2]	[50.8]	[19.1]	[19.1]	[25.4]
[45t]	[73.7]	[98.0]	[368.3]	[317.5]	[81.3]	[62.0]	[69.9]	[25.4]	[25.4]	[38.1]

Capacities are in pounds [kg/t].

**SPECIFICATIONS**

PARAMETER	VALUE			UNIT
Rated capacity-R.C. ( $E_{max}$ )	25K, 40K, 50K, 60K, 75K, 100K, 125K 10t, 25t, 35t, 45t			lbs kg/metric tons
NTEP/OIML Accuracy class	NTEP IIII	Standard	OIML R60	
Maximum no. of intervals (n)	10000 multiple		3000	
$Y = E_{max}/V_{min}$	See NTEP cert. 86-045A1		6250	Maximum available
Rated output-R.O.	3.0			mV/V
Rated output tolerance	0.25			±% mV/V
Zero balance	1.0			±% FSO
Combined error	0.02	0.03	0.02	±% FSO
Non-repeatability	0.01			±% FSO
Creep error (30 minutes)	0.025	0.03	0.017	±% FSO
Temperature effect on zero	0.0009	0.0015	0.0010	±% FSO/°F
Temperature effect on output	0.0008	0.0008	0.0007	±% of load/°F
Compensated temperature range	14 to 104 (-10 to 40)			°F (°C)
Operating temperature range	0 to 150 (-18 to 65)			°F (°C)
Storage temperature range	-60 to 185 (-50 to 85)			°F (°C)
Sideload rejection ratio	500:1			
Safe sideload	100			% of R.C.
Maximum safe central overload	150			% of R.C.
Ultimate central overload	300			% of R.C.
Excitation, recommended	10			Vdc or Vac rms
Excitation, maximum	25			Vdc or Vac rms
Input impedance	686 - 714			Ω
Output impedance	699 - 707			Ω
Insulation resistance at 50VDC	>1000			MΩ
Material	Nickel plated alloy tool steel*			
Environmental protection	IP67			

Note: \* Stainless steel available as 65040W  
FSO - Full Scale Output

All specifications subject to change without notice.



[www.thescaleshop.net](http://www.thescaleshop.net)

1-888-844-2031

